

---

# **LECTURE NOTES ON MANUFACTURING TECHNOLOGY**

**4<sup>TH</sup> SEMESTER  
MECHANICAL ENGINEERING**

**PREPARED BY:-  
Mr. A. SUDHIR KUMAR  
LECTURER  
GOVT. POLYTECHNIC, KORAPUT**

---

---

Name of the Course: Diploma in Mech/Auto/ & Other Mechanical Allied Branches

---

Course code:	TH-2	Semester	4th
Total Period:	60	Examination	3 hrs
Theory periods:	4 P/W	Class Test:	20
Maximum marks:	100	End Semester Examination:	80

---

### TOPIC WISE DISTRIBUTION OF PERIODS

Sl. No.	Topic	Periods
01	Tool Materials	04
02	Cutting Tools	06
03	Lathe Machine	08
04	Shaper	06
05	Planing Machine	06
06	Milling Machine	08
07	Slotter	06
08	Grinding	06
09	Internal Machining operations	06
10	Surface finish, lapping	04
<b>Total Periods</b>		<b>60</b>

## CONTENT

### **Tool Materials**

Composition of various tool materials  
Physical properties & uses of such tool materials.

### **Cutting Tool**

Cutting action of various hand tools such as Chisel, hack saw blade, dies and reamer  
Turning tool geometry and purpose of tool angle  
Machining process parameters  
Coolant and lubricant in machining purposes

### **Lathe Machines**

Construction and working of lathe

- Major components of a lathe and their function
- Operations carried out in a lathe (Turning, thread cutting, taper turning, internal machining, parting off, facing, knurling)
- Safety measures during machining

### **Capstan Lathe**

- Difference with respect to engine lathe
- Major components and their function

- Define multiple tool holders

# MANUFACTURING TECHNOLOGY

---

## Turret Lathe

- Difference with respect to capstan lathe
- Major components and their function

Draw the tooling lay out for preparation of a hexagonal bolt & bush

## Shaper Machine

Potential application areas of a shaper machine  
Major components and their function  
Explain the automatic table feed mechanism  
Explain the construction & working of tool head  
Explain the quick return mechanism through sketch  
State the specification of a shaping machine.

## Planing Machine

Application area of a planer and its difference with respect to shaper  
Major components and their functions  
The table drive mechanism  
Working of tool and tool support  
Clamping of work through sketch.

## Milling Machine

Types of milling machine and operations performed by them  
Construction & working of simple dividing head, universal dividing head

Procedure of simple and compound indexing

Illustration of different indexing methods

## Slotter

Major components and their function  
Construction and working of slotter machine  
Tools used in slotter

## Grinding

Significance of grinding operations  
Manufacturing of grinding wheels  
Criteria for selecting of grinding wheels

Specification of grinding wheels with example

Working of

- Cylindrical Grinder
- Surface Grinder
- Centreless Grinder

## Internal Machining operations

Classification of drilling machines

Working of

- Bench drilling machine
- Pillar drilling machine
- Radial drilling machine

Boring

- Basic Principle of Boring

# MANUFACTURING TECHNOLOGY

---

- Different between Boring and drilling

## Broaching

- Types of Broaching(pull type, push type)
- Advantages of Broaching and applications

## **Surface finish, lapping**

Definition of Surface finish

Description of lapping& explain their specific cutting.

**Tool Materials**

## **Chapter-1**

### **Manufacturing technology:**

It is defined as a field of study focused on process techniques or equipments, cost reduction, increased efficiency, enhanced reliability, security safety and anti-pollution measures are its objects.

### **Tool Material:**

The characteristic of the ideal cutting tool material are-

- (a) Hot hardness**
- (b) Wear resistance**
- (c) Toughness**
- (d) Cost and easiness in fabrication**

# MANUFACTURING TECHNOLOGY

---

## **Hot hardness:**

The material must remain harder than the work material at elevated operating temperatures.

## **Wear resistances:**

The material must withstand excessive wear even through the relative hardness of the tool-work materials changes.

## **Toughness:**

The term toughness actually implies a combination of strength and ductility. The material must have sufficient toughness to withstand shocks and vibrations and to prevent breakage.

## **Cost and easiness in fabrication:**

The cost and easiness of fabrication should have within reasonable limits.

## **State the composition of various tool material**

The cutting tool materials are:-

1. Carbon steels
2. Medium alloy steel
3. High speed steels
4. Stellites
5. Cemented carbides
6. Ceramics
7. Diamonds
8. Abrasives
9. Cubic boron nitride(CBN)

# MANUFACTURING TECHNOLOGY

---

## **Composition of carbon steels:**

Carbon steels contain carbon in amounts ranging from 0.008 to 1.5%

## **Composition of medium alloy steel:**

The high carbon medium alloy steels have a carbon content akin to plain carbon steels, but in addition there is, say up to 5% alloy content consisting there of tungsten, molybdenum, chromium and vanadium.

## **Composition of high speed steel:**

High speed steel is the general purpose metal for low and medium cutting speed owing to its superior three type of high speed steel

1. **High tungsten**
2. **High molybdenum**
3. **High cobalt**

Actually these three named modify as following

1. 18-4-1 high speed steel (T-series)
2. Molybdenum high speed steel (M-series)
3. Cobalt high speed steel

## **Composition of 18-4-1 high speed steel (T-series)-**

This steel containing 18% tungsten, 4% Cr & 1% vanadium, is considered to be one of the best of all purpose of tool steel.

## **Composition of molybdenum high speed steel (M-series):**

This steel containing 6% Molybdenum, 6% W, 4% Cr % & 2% vanadium.

## **Composition of cobalt high speed steel:**

This is sometimes called super high speed steel. Cobalt is added from 2 to 15% to increase of the steel contain 20% tungsten 4% Cr, 2% V & 12% cobalt.



# MANUFACTURING TECHNOLOGY

---

## **Composition of satellites:**

Satellites are the trade name of a nonferrous cost alloy cobalt, chromium and tungsten. The ranges of elements in these alloys is 40 to 48%, 30 to 35% Cr & 12 to 19% tungsten.

## **Composition of cemented carbides:**

A typical analysis of a carbide suitable for steel machining is 82% tungsten carbide, 10% titanium carbide and 8% cobalt.

## **Composition of ceramics:**

The latest development in the metal cutting tools use Al<sub>2</sub>O<sub>3</sub> oxide generally referred to as ceramics

Tools are made by composing aluminium oxide powder in a mould at about 280 kg/cm<sup>2</sup> or more.

## **Composition of diamonds:**

The diamonds used for cutting tools are industrial diamonds, which are naturally occurring diamonds.

## **Composition of abrasive:**

Abrasive grains in various forms, loose, bonded into wheels and extended in papers and stony and extended in papers and cloths find wide application in industry. They are mainly used for grinding harder materials and where a superior finish is desired on hardened or unhardened materials.

## **Composition of Cubic Boron Nitride (CBN):**

This material consisting atoms of boron and nitrogen is considered as the hardest tool material available.

## **Physical properties and user of different types of tool material:**

The various type of tool materials are:

1. Carbon steel
2. Medium alloy steel
3. High speed steel
4. Cast alloy satellites
5. Cemented carbide tool material
6. oxide or ceramic tool material
7. diamonds
8. abrasives
9. cubic boron nitride(CBN).

### **Carbon steel:**

#### **Properties**

- I. low hot hardness
- II. poor harden ability
- III. can be withstand cutting temperature  $200^{\circ}\text{c}$
- IV. carbon tool steel are harder than many hss

**uses:** It can be used most economically under these condition.

- (a) The carbon steels are used for making certain taps and drills.
- (b) For making wood working tools

### **Medium alloy steel:**

#### **Properties**

- i) Better hardenability.
- ii) Higher wear resistance.
- iii) Higher hardness.

#### **Uses**

- i) Used for making drills
- ii) Used for making taps, etc
- iii) It can aut effectively up to temperature  $250$  to  $300^{\circ}\text{c}$ .

## **High speed steel (HSS):**

### **Properties**

- i) High hot hardness
- ii) Cutting tools retain the cutting ability upto 600<sup>0</sup> c.
- iii) High wear resistance.
- iv) The hardenability is good.

### **Uses**

- i) Drills
- ii) Broaches
- iii) Milling cutters
- iv) Lathe cutting tools
- v) Taps,etc.,

## **Cast alloy satellite:**

### **Properties:**

- i) Material is not so hard at room temperature
- ii) Hardness above 1000<sup>0</sup>F is greater than high speed steels.
- iii) Hat hardness is higher than H.S.S at higher temperature.
- iv) This material is very brittle

### **Uses**

These material are used extensively in some non metal cutting application such as rubbers, plastics.

## **Cemented Carbide:**

### **Properties:**

- i) High hardness
- ii) High heat resistance
- iii) High wear resistance
- iv) High hot hardness upto a temp. of 900<sup>0</sup> c
- v) Low specific heat

# MANUFACTURING TECHNOLOGY

---

## **Uses:**

These tool materials are used for machining cast iron, alloy steels.

## **Oxides ceramic tool material:**

### **Properties:**

- I) The ceramic has extremely high compressive strength. It is quietly brittle.
- II) Heat conductivity is very low. So generally no coolant is required while machining
- III) The ceramic tools can retain strength and hardness upto 1200<sup>0</sup>c.

### **Uses:**

These tool materials are used for turning boring, etc operations at high speed.

## **Diamonds are cutting tools:**

### **Properties:**

- i) It has a low co-efficient of friction
- ii) Hardness of the diamond is incompressible.

### **Uses:**

Diamonds are suitable for cutting very hard material such as glass, plastics, ceramics.

## **Abrasive:**

### **Uses:**

For most grinding operations there are two kinds of abrasives in general use namely aluminium oxide and silicon carbide. The aluminium oxide abrasive are used for grinding all high tensile materials, where as Silicon Carbide abrasives are more stable for low tensile materials

## Chapter-2

# Cutting Tools

### **Cutting tools:**

In machining a cutting tool or cutter is any tool which is used to remove the material from the W/P by means of shear difference

Cutting tool must be made of a material harder than the material which is to be cut and the tool must be to withstand the heat generated in the metal cutting process

The angle of cutting facer is also important, also the tool must have a specific geometry and clearance angles designed so that the cutting edge can contact the W/P surface .

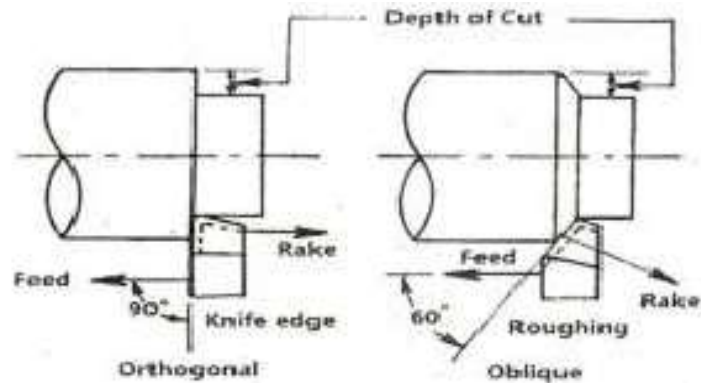

**Figure Orthogonal and oblique cutting**

### Single point cutting tool

This type of cutting tools have only one cutting edge. These used for wide application of lathe, shaper planner, slitter, boring M/C

Multi point cutting tools

This type cutting tools have more than cutting edge. These are employed for wide application in twist drills, Reamers, tapes, milling cutters etc.

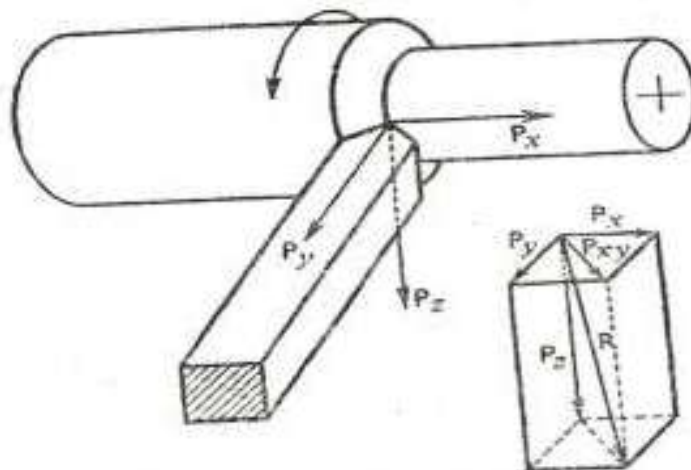

**Figure Cutting forces in conventional turning process**

## Cutting action of hand tools

### Chisel:

A chisel is a hand cutting tool which is shaped cutting edge of blade on its end, for carving, cutting a hard material such as wood, stone, metal by hand with the help of mechanical power.

In use the chisels are forced in to the material to linear relative motion.

The driving force into the material may be manually applied by using a hammer.

In industrial use, a hydraulic ram or falling weight drives the chisel into the material to be cut.

Chisel is employed to use in wood work, metal working etc.

In wood & stone working used for carving, cutting, shaving, shaping, trimming.

In metal working process chisel use divided into two categories:

### Cold chisel:

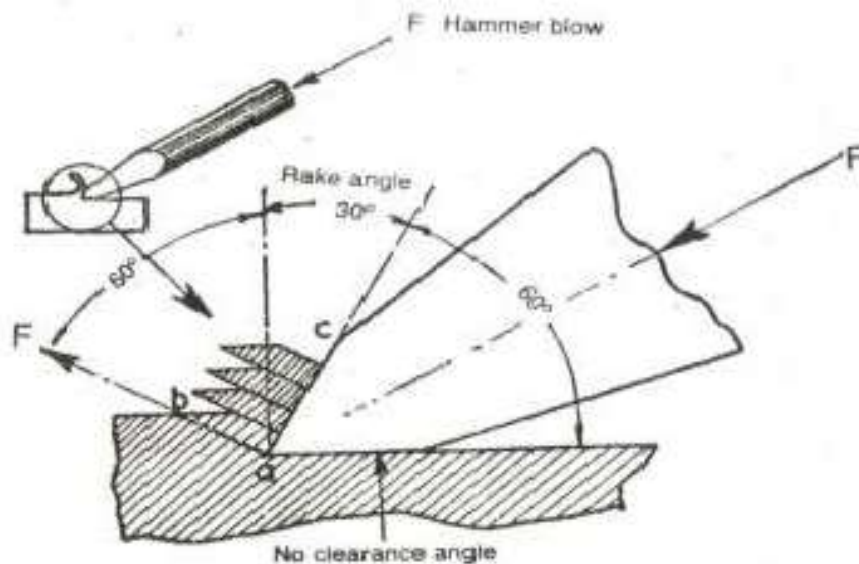

Figure Shearing action of a cold chisel

# MANUFACTURING TECHNOLOGY

---

It is made of from tempered steel.

Use for cutting cold metal.

Used to remove waste metal in the situation where a smooth finish is not necessary or when other tools such as file, hacksaws cannot be used .

## Hot chisel:

A hot chisel is used to cut metal that has been heated in a force to sustain the metal.

Used to smooth the metals.

## Hacksaw blade

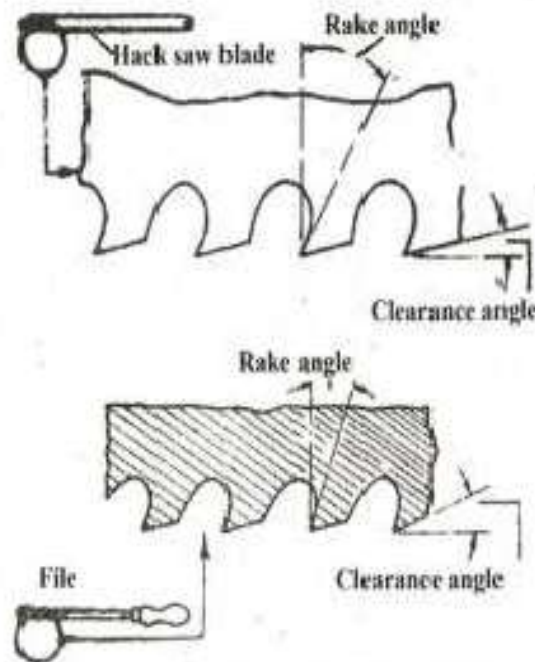

**Figure** Rake and clearance angles on hack saw blade and file

Hacksaw blade is a fine toothed saw, originally principally for cutting metal.

They can also cut various other materials such as plastic & wood.

There are hand saw various & power various



## MANUFACTURING TECHNOLOGY

---

When attached to a C-shaped frame which holds a blade under tension.

The frames may be adjustable to accommodate blades of different sizes.

Blades are available in standardized lengths, usually 10<sup>11</sup> or 12<sup>11</sup> for a standard hand hack-saw.

The pitch of the teeth can be anywhere from 14 to 32 per inch for a hand blade & for large power hack saw blade there are 3 tpi

As hack-saw teeth are so small, they are set in a wave set.

As the blades are normally quite brittle, so proper care should be taken to prevent fracture of the blade.

Blades are made of carbon steel or low alloy steel.

But for several decades now, hack-saw blades have used HSS for their teeth, giving great improved cutting & tooth life.

On hack-saw the blade can be mounted with the teeth facing toward or away from the handle

Resulting and cutting action on either pushes or pull stroke.

In normal use, cutting vertically downwards with work held in a bench, vice, the saw blade Should be set to be face forward.

### **Die:**

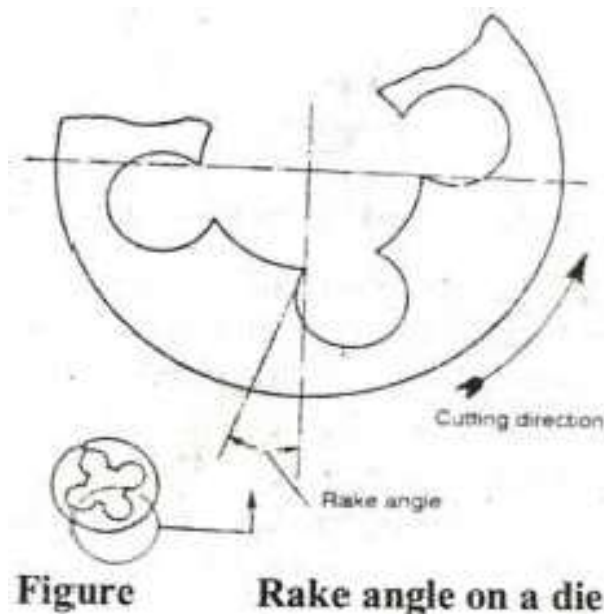

## MANUFACTURING TECHNOLOGY

---

Die cutting is the process of using die to shear webs of low strength material such as rubber, timber, cloth, plastic, sheet metal etc.

Die cutting can be done on either flat bed or by rotary process .

Rotary die cutting is die cutting using a cylindrical die or a rotary processes .

Dies are used to cut the external thread on the rod or pipe end.

Dies are made of high carbon steel or HSS .

The process of cutting external thread by dies is called dieing .

Turning is also known as die cutting, is a process which cuts stock without formation of chips or the off during or melting.

The die cutting action can be controlled by electric, hydraulic, pressurized or manual surfaces.

### **Reamer:**

- > It is a multiple edge cutting tools.
- > The process of enlarging the hole is called reaming.
  - > There are many different types reamer and there may be designed for used as a hand tool or in a M/C tool such as milling M/C or drill press.
  - > A typical reamer consists of a set of parallel straight or helical cutting edge along the length of a cylindrical body
  - > Each cutting edge is grounded at a slight angle and with slight undercut below the cutting edge
  - > This may be used to remove small amount of material.
  - > Reamers are made of high Carbon or Plain Carbon

Steel

Reamers are of two types

- > Hard Reamers
- > Machine Reamers

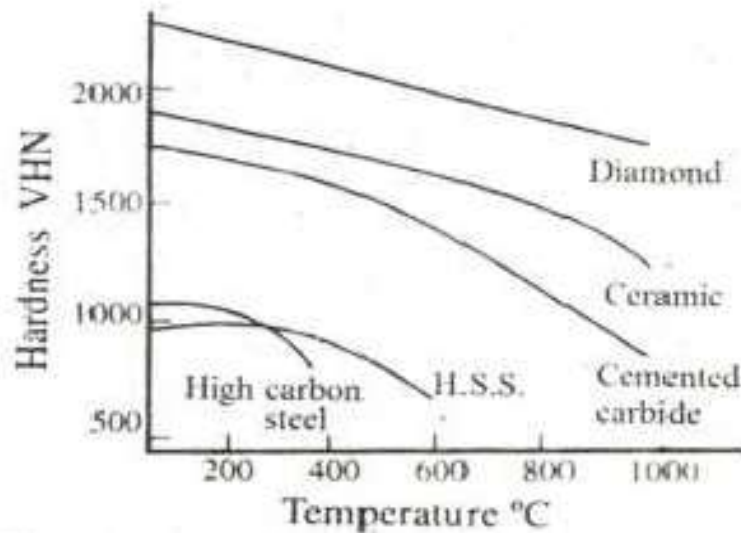

**Figure** Hardness profiles of cutting tool materials

## **Machining Process Parameters:**

Factors affecting tool life:

The life of a tool is affected by many factors such as: cutting speed, feed, depth of cut, chip thickness tool geometry, material of cutting fluid, and rigidity of the machine

## **Cutting Speed:**

The cutting speed can be defined as the relative surface speed between the tool and the job or the amount of length that will pass the cutting edge of the tool per unit of time.

It may be defined as the speed which the cutting edge pass over the material. It is expressed in meters per min (mpm).

## **Feed:**

It is defined as the relation by small movement per cycle of the cutting tool, relative to the workpiece in a direction which is usually to the cutting speed direction.

Or

It is the distance the tool advances into or along the work piece. Each time the tool point passes a certain position in its travel over the surface. It is expressed as mm/tooth.

### **Depth of cut:**

The depth of cut is the thickness of the layer of metal removed in one cut or pass, measured in a direction perpendicular to the machined surface.

It is the vertical distance the tool advances into the work piece during one revolution of job it is expressed in mm.

### **Selection of cutting speed, feed & depth of cut:**

- Hard and strong materials require a lower cutting speed, soft & ductile materials require higher cutting speeds.
- For light finishing cut – fine feed & higher speed roughing cut – low feed & lower cutting speed.
- Large depth of cut – roughing operation
- Small depth of cut – finishing operation
- Cemented carbide, ceramics, satellite &
- Hss – high cutting speed tool
- Alloy or carbon steel tools – lower cutting speed.

### **Coolants & lubricants:**

Cutting fluid sometimes referred to as lubricants or coolants are liquids and gases applied to the tool and work piece to assist in the cutting operations.

## **Purpose of cutting fluid:**

- To cool the tool
- To cool the work piece
- To lubricate and reduce friction
- To improve surface finish
- To protect the finished surface from corrosion
- To cause chips break up into small parts
- To wash the chips away from the tool

## **Properties of cutting fluids:**

1. High heat absorption for readily absorbing heat developed.
2. Good lubricating qualities to produce low-coefficient of friction.
3. High flash point so as to eliminate the hazard of fire
4. Stability so as not to oxidize in the air
5. Neutral so as not to react chemically
6. Colorless so as not to produce any bad smell even when heated.
7. Harmless to the bearings.
8. Harmless to the skin of the operators
9. Non-corrosive to the work or the machine
10. Transparency so that the cutting action of the tool may be observed.
11. Low viscosity to permit flow of the liquid
12. Low priced to minimize production cost.

## **Choice of cutting fluids:**

1. Type of operation
2. The rate of metal removal
3. Material of the work piece
4. Material of the tool
5. Surface finish requirements
6. Cost of cutting fluid.

## **Type of cutting fluids:**

### **Water:**

Pure water is the best cutting fluid available because of its highest heat carrying capacity. But water corrodes the material very quickly so water containing alkali, salt or water-soluble additive but little or no oil or soap are some times used as coolant.

### **Soluble oils:**

These are emulsions composed of around 80% or more water, soap & mineral oil. The soap acts as an emulsifying agent which breaks the oil into minute particles to disperse them throughout the water. The water increase the cooling effect and the oil provide the lubricating properties.

### **Straight oils:**

The straight oils may be

- a) Straight mineral oils, kerosene, low-viscosity petroleum fraction such as mineral seal, or higher viscosity mineral oils
- b) Straight fixed or fatty oils consisting animal, vegetable or synthetic equivalent, lard oil etc.
- c) They have both cooling and lubricating properties

# MANUFACTURING TECHNOLOGY

---

## **Mixed oils:**

This is a combination of strength mineral and strength fatty oil. This makes oil excellent lubricant and coolant for atmospheric screw-machine work.

Chemical additive oil: straight oil or mixed oil when mixed-up with sulphur or chlorine is known as chemical additive oil. Sulphur and chlorine are used to increase both lubricating and cooling qualities. These oils used for machining tough, strong low carbon steels.

Chemical compounds: these compounds consist mainly of a rust inhibitor, such as sodium nitrate, mixed with a high percentage of water.

Solid lubricants: stick waxes. And bar soaps are sometimes used as lubricants.

Metal cutting and cutting tools : in the metal working industry the various working processes fall into groups.

Not-cutting shaping – forging, pressing, drawing

Cutting shaping – turning, drilling, milling.

## **Cutting tools**

A cutting tool may be used either for cutting a part or for removing chips.

Cutting tools are mainly divided into two groups.

- Single point cutting tool
- Multipoint cutting tool

A single point cutting tool consists of a sharpened cutting part called its point.

Ex: lathes, slotting machines

Multipoint cutting tools have arrangement of two or more single point tools as a unit.

Ex – milling cutting, broaching tool, twist drill.

## **Cutting tool nomenclature:**

It means schematic naming of the various parts and angles of a cutting tool.

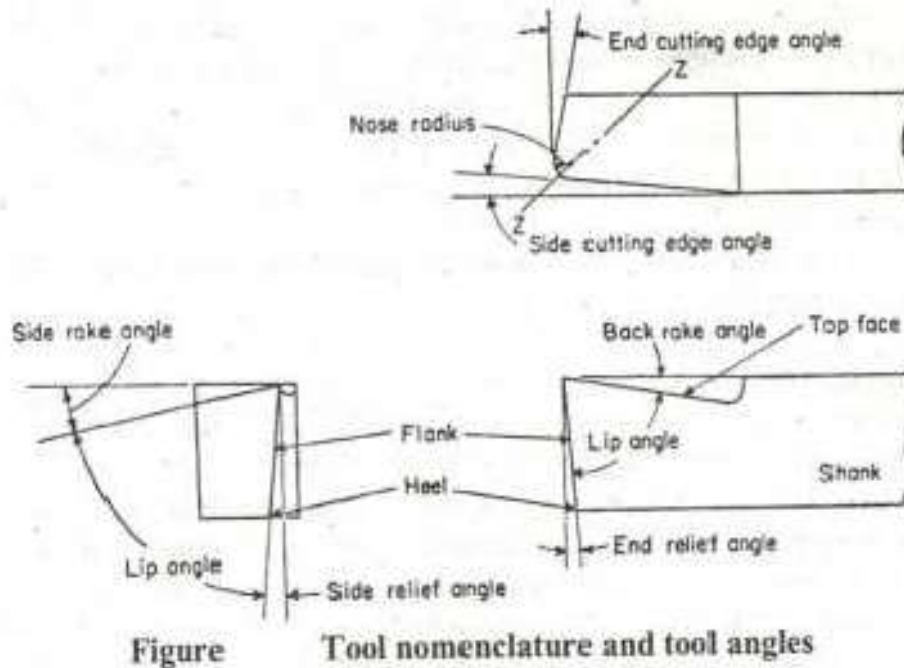

## **Shank:**

It is the main body of the tool.

## **Flank:**

The surface or surfaces below and adjacent to the cutting edge is called flank of the tool.

## **Heel:**

It is the intersection of the flank and the base of the tool.

## **Nose:**

It is the point where the side cutting edge and end cutting edge intersection.



## **Cutting edge :**

It is the edge on the face of the tool which removes the material from the work piece. The total cutting edge consists of major edge (major), end cutting edge (minor) and the nose.

## **Face:**

The surface against which the chip slides upward.

## **Base:**

It is the underside of the shank.

## **Rake:**

It is the slope of the tool away from the cutting edge. Larger the rake angle, the cutting force and power reduce.

Designation of cutting tools: there are two systems to designate the tool shape

1. **American standards association system (ASA)**

Or

American national standards institute (ANSI)

2. **Orthogonal rake system. (ORS)**

The various tool angles are:

1. **Side cutting edge angle (Cs): (Lead angle)**

The angle between the side cutting edge and side of the tool shank

2. **End cutting edge angle (Ce):**

This is the angle between the end cutting edge and a line normal to the tool shank

# MANUFACTURING TECHNOLOGY

---

## **Side relief angle:**

It is the angle between the portion of the side flank immediately below the side cutting edge and a line perpendicular to the base of the tool measured at right angle to the side flank.

## **End relief angle**

It is the angle between the portion of the end flank immediately below the side cutting edge and a line perpendicular to the base of the tool measured at right angle to the end flank.

## **Back rake angle:**

It is the angle between the face of the tool and a line parallel to the base of the tool and measured in a plane perpendicular to the side of the cutting edge. The angle is +ve – If side cutting edge slopes downwards from the point towards the shank.

-ve – if the slope of the side cutting edge is reverse.

## **Side rake angle :**

It is the angle between the tool face and a line parallel to the base of the tool and measured in a plane perpendicular to the base and side cutting edge. This angle gives slope of the face of the top from the cutting edge.

The angle is – ve – if the slope is towards the cutting edge

+ve - If the slope is away from the cutting edge

## **Purpose of tool angles**

**Cs** – It is the angle which prevents interference as the tool enters the work material. This angle affects tool life and surface finish 15° to 30° is kept for general machining.

**Ce** – It provides a clearance or relief to the trailing end of the cutting edge to prevent rubbing or drag between the mechanical surface and the non cutting part of the cutting edge 8° to 15° is satisfactory.

## MANUFACTURING TECHNOLOGY

---

These angles are provided so that the flank of the tool clears the workpiece surface and there is no rubbing between them  $5$  to  $15^\circ$  is given.

Larger the rake angle smaller the cutting angle and lower the cutting force and power

The rake angle is small for cutting hard materials and large for cutting soft ductile materials. It may be – ve or zero.

A flat cold chisel is a single point tool used at the bench and the point is considered as wedge.

For mild steel a rake angle of  $30^\circ$  and wedge angle of  $60^\circ$  are recommended

Using a cold chisel with no clearance angle, the loss through friction is small as the cutting point is in contact with the metal

The force hammer blow  $F$  is transmitted at approximately  $90^\circ$  to the cutting face  $ac$  and this sets up shear stress across the shear plane  $ab$ .

If the hammer blow is heavy as  $F$ , the metal will shear across the shear plane and move up to the face  $ac$  as continuous chip.

The energy required to shear the metal will be the shearing force along the shear plane and this force is proportional to the length of the shear force is proportional to the length of the shear plane and the greater the energy required to the shear of metal

A hack saw blade is a multi-point tool and has a very large number of wedges like points each with its own rake and clearance angle.

The rake is necessary but too much rake makes the tooth weak

A large amount of energy would be lost in overcoming the frictional forces set up if there is clearance.

The hollow space between each tool is sloped more sharply to give the form if this would be too

Shallow it would be closed with chips of the metal being cut

## MANUFACTURING TECHNOLOGY

---

Taps are used for cutting internal threads on work materials. it consists of a no of teeth arranged uniformly across the whole die body when it rotates in a particular direction i.e clockwise or anticlockwise .

The rake angle is provided to reduce the shear forces during cutting & less torque will be required to shear the metal. There is no provision for clearance angle in the die.

It is a multi point cutting tool used for enlarging or finishing a previously drilled or bore hole to give a good finish and accurate dimension. It removes very small amount of material from the work piece.

## Chapter-3

### **Lathe Machine**

## **Lathe machine:**

The lathe machine is the one of the oldest machine tools and came the early tree lathe which was a device for rotating and machining a piece of lathe between two adjacent trees. a rope would round the work with its one end attached to a flexible branch of trees and end is pulled by a man to rotate the job hard tools are used them.

## **Function of lathe machine:**

The main function of lathe machine is to remove metal from a piece of work to give it the required shape and size. The work is held securely and rigidly on the machine and then turn against the cutting tools which is remove metal from the work in the forms of chips.

## **Types of lathe:**

- **speed lathe:**
  - **Wood working**
  - **Centering**
  - **Polishing**
  - **Spinning**
- **Engine lathe:**
  - **belt drive**
  - **Individual motor drive**
  - **Gear head lathe**
- **Bench lathe:**
- **Tool room lathe**
- **Caps & turret lathe**
- **Special purpose:**
  - **Wheel lathe**
  - **Gap bed lathe**
  - **Turret lathe**
  - **Duplicating lathe**
- **Automatic lathe:**

# MANUFACTURING TECHNOLOGY

---

## **The speed lathe:**

- It is the simplest of all types of lathe.
- It consists of a bed, headstock, a tailstock and a tool post mounted on an adjusted slide.
- There is no feed box, lead screw or conventional type carriage.
- The tool is mounted on the adjustable slide and is fed into work purely by hand control.
- Spindle speed is very high.(range from 1200 to 3600 rpm).
- This is used for work requiring, spinning, centering, polishing.

## **The engine lathe or centre lathe:**

- The engine lathe in the early days was driven by steam engines
- It consists of bed, head stock, and tail stock.
- More robust head stock and contains mechanism for driving the spindle at multiple speeds.
- Belt driving lathe – receives power from an overhead live shaft
- Individual motor drive- receiving power from an individual motor
- Gear head lathe –gets power from a constant speed motor.

## **The bench lathe:**

- The small lathe mounted on a bench
- It consists of all the parts but small in size.
- It is used for small & precision work.

## **The tool room lathe:**

- It is similar to engine lathe.
- It has spindle speeds ranging from very low to high up to 2500 rpm.
- It consists of chuck, taper turning attachment, thread chasing dial, steady rest, coolant etc.
- This is used for precision work on tools, dies, gauges & for accuracy works

# MANUFACTURING TECHNOLOGY

---

## **Capstan and turret lathe:**

- › This is the development over engine lathe.
- › The tail stock is replaced by a hexagonal turret, on the face of which multiple tools are fitted
- › Several operations can be done on a work piece without resetting of work or tools & a no. of identical parts can be produced in minimum time.

## **Special propose lathe:**

- › They are used for special proposes.
- › The Wheel lathe – for finishing journals & turning the thread on rail road car and locomotive wheels gap bed lathe- to swing extra large diameter pieces.
- › T-lathe – for machining of motor for jet engines the axis of the lathe bed is right angles to the axis of the head store spade.
- › Duplicating lathe used for duplicating the shape of a flat or round template on the work piece

## **Automatic lathe:**

- › These are high speed, heavy duty, mass production lathes with complete automatic control.
- › After the tools are set and the machine is started it performs automatically all the operations to finish the job.
- › The changing of tools, speed s and feeds are done automatically.
- › After the job is complete, the machine will continue to repeat the cycles producing identical parts.



## **Specification of lathe :**

- The height of the centres from the bed.
- The swing diameter over bed. This is the largest diameter of work that will revolve without touching the bed and is twice the height of the centre measured from the bed of the lathe.
- The length between the centers. This is the max height of work that can be mounted between the lathe centres.
- The swing dia over carriage. This is the biggest dia of work that can be less than the swing dia over bed. This is the maximum bar stock will pass through hole of the headstock spindle .
- The length of the bed: This indicates the approx. floor space occupied by the lathe

The work piece is held in a chuck or between centers and rotated its axis at uniform speed .the within tool held in the tool post is fed in to the work spices for a desired depth. the tool may be given linear motion in may direction salve there is a relative motion between the work piece and tool , the material is removed the form of chips & desired shape is obtained .

## Different parts of a lathe :

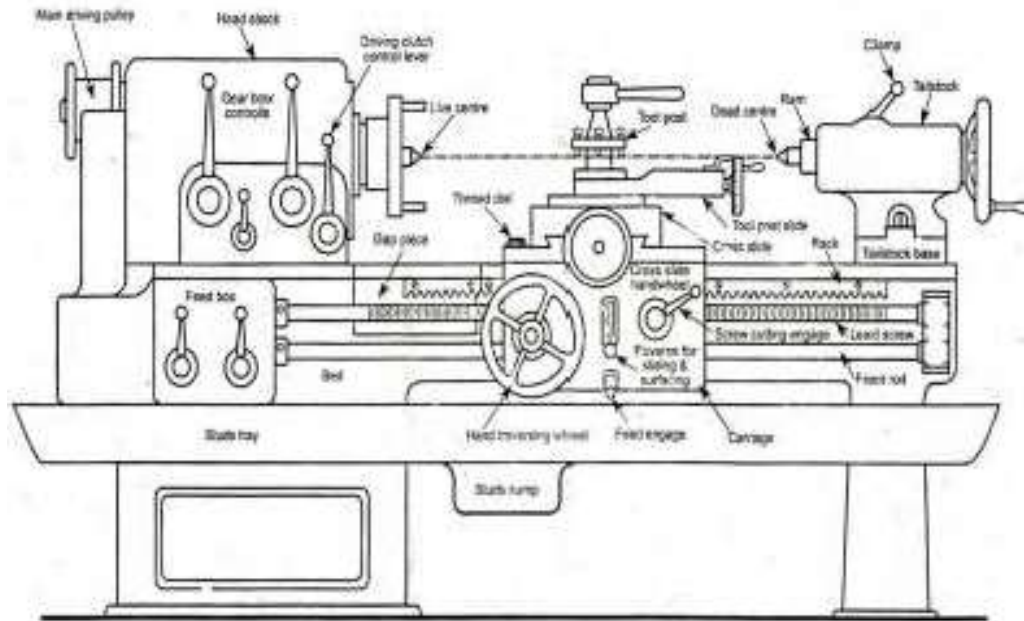
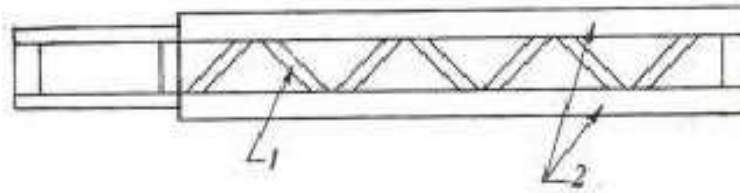

Figure 3.2 Lathe parts

1. Bed
2. Head stock
3. Tail stock
4. Carriage
5. Feed mechanism
6. Screw cutting mechanism

### **BED:**

The bed is the base or foundation of the lathe. It is made of cast iron. It is a massive and rigid casting made in one piece to resist deflection and vibrations. It supports the head stock, tail stock and carriage. On the top of the bed, there are two sets of slides or guide ways. The outer ways for carriage and inner ways for the tail stock. The guide ways may be flat and inverted –v having included angle of  $90^{\circ}$



**Figure Lathe bed diagonal ribs**  
1. Diagonal rib, 2. Bedways.

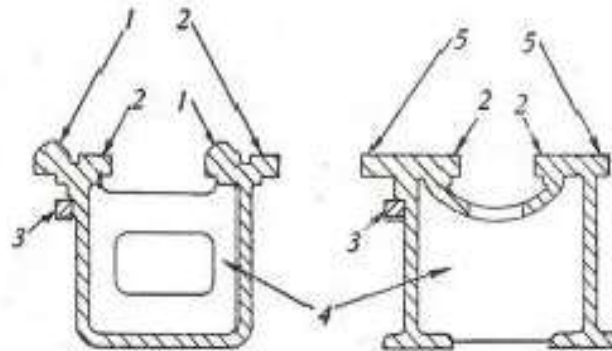
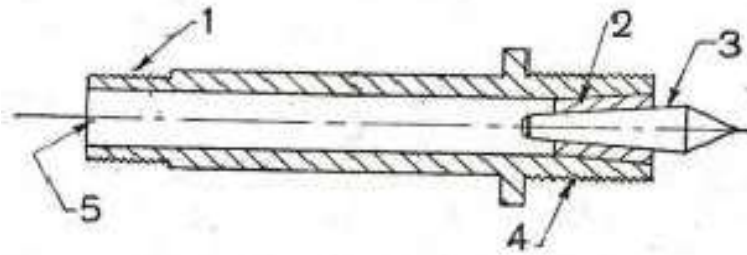

**Figure Types of lathe bedways**  
1. Inverted-V bedway, 2. Flat bedways, 3. Back, 4. Box section, 5. Flat bedways for saddle.

## **Head stock:**

The head stock assembly is permanently fastened to the left hand end of the lathe. It provides mechanical means of rotating the work at multiple speeds.

The spindle of head stock is made of carbon or nickel chrome steel. It protrudes from gear box and contains means for fast ending work holding derives like chuck, face plate, dog plats, live centred spindle nose is turned so that face plate or chuck can be mounted on it hold and rotate the work piece. Hollow spindle is tapered at the nose to receive the live centre.



**Figure 3.6 Headstock spindle**  
1. Threaded end, 2. Taper sleeve, 3. Live centre,  
4. Threaded nose, 5. Spindle hole.

Spindle is hollow throughout its length through which long bar stock can be fed. The size of spindle hole determines the max'm size of bar stock that can be machined

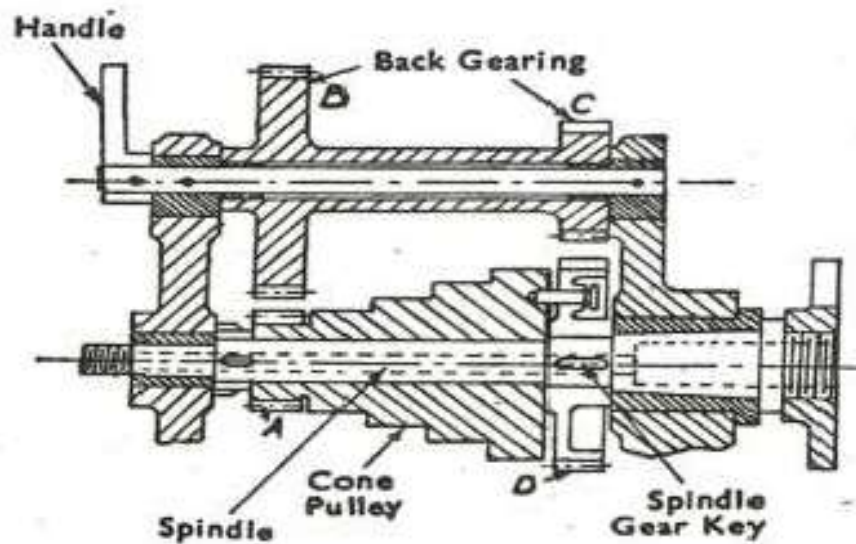
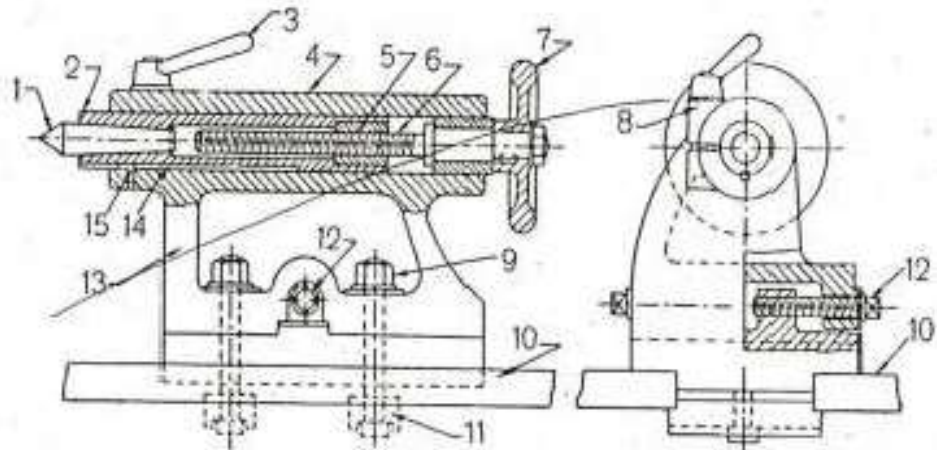

**Figure Backgeared headstock**  
lever by simply pulling a cord.

Power is supplied from an electric motor or V-belt.

## **Tail stock or loose head stock:**

The tail stock is located at on the inner ways at the right hand end of the bed and it is a non-rotating part which slides and can be clamped to it. any position to accommodate different lengths of work pieces.



**Figure Tailstock**

1. Dead centre, 2. Spindle, 3. Spindle clamp, 4. Barrel, 5. Bush, 6. Square threaded screw, 7. Hand wheel, 8. Split lug, 9. Tailstock clamping bolt, 10. Lathe bedways, 11. Clamping plate, 12. Setover screw, 13. Body, 14. Keyway, 15. Key.

It has two uses:

1. Supports the other end of the work when it is machined between two centres.
2. To hold a tool for per forming operations such as drilling, reaming, tapping etc.

## **CARRIAGE:**

In between the head stock and tail stock is the carriage. It is movable on the bed ways and its purpose is to hold the cutting tool and to impart to it either longitudinal or cross feed. It consists of the following parts:

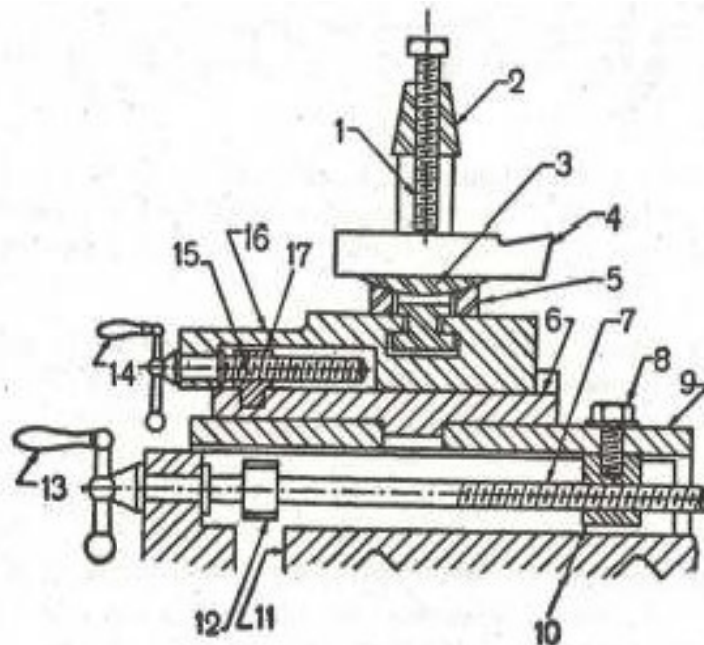

**Figure 3.10 Carriage**

1. Toolpost screw, 2. Tool post, 3. Rocker, 4. Tool, 5. Concave ring, 6. Compound rest swivel base, 7. Crossfeed screw, 8. Binder screw, 9. Cross slide, 10. Cross slide nut, 11. saddle, 12. Pinion on Crossfeed screw for automatic feed, 13. Cross slide hand wheel, 14. Compound slide hand wheel, Compound slide feed screw, 16. Compound rest, 17. Compound slide nut.

## 1. Saddle:

It is an H-shaped casing that fits over the outer ways of the bed. It carries the cross-slide and tool post.

## 2. Cross slide:

It is mounted on saddle. It provides cutting tool motion which is to the centre like of the lathe. This is known as cross slide can be moved by means of feed screw, which is controlled by a small hand wheel or by power feed.

### 3. Compound rest:

It is mounted on the top of the cross slide. It supports the tool post. It has a graduated base and can be swiveled around a vertical axis. It can be swivelled around a vertical axis. It can be moved by means of a screw which is controlled by a small hand wheel and graduated dia & not by power feed.

### 4. Tool post:

It is mounted on the top of the compound rest to hold the tool. The tool post can be moved on the compound rest and can be clamped in any position. It can be rotate also to hold the cutter in desired angle. 1. single tool post 2. Four bolt 3. Open side 4. Four way

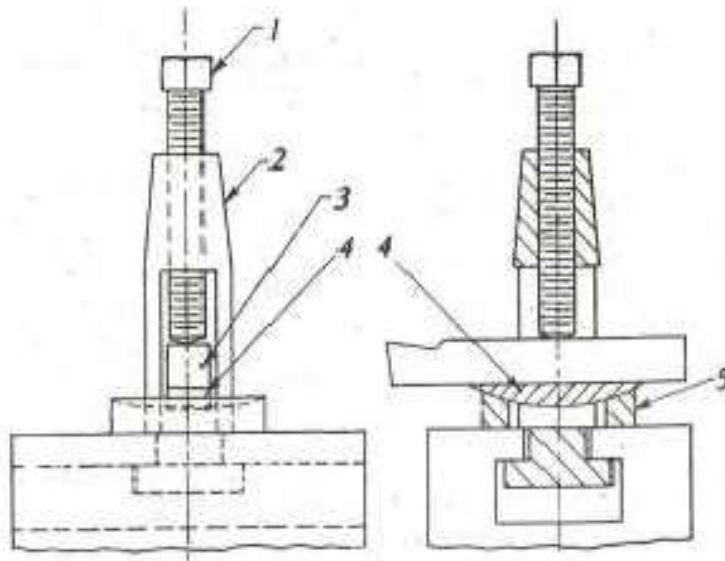
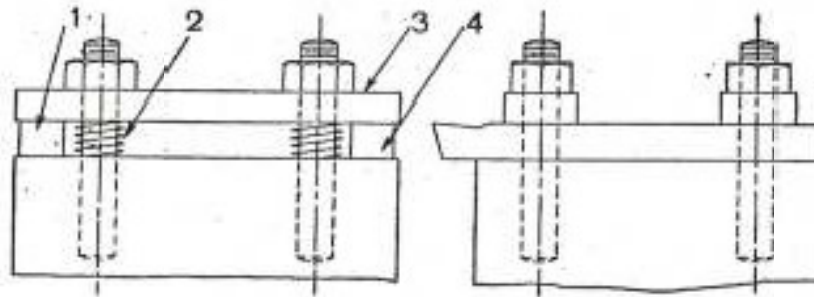

**Figure Single screw toolpost**

1. Toolpost screw, 2. Toolpost body, 3. Tool, 4. Convex rocker, 5. Concave ring.

## 102 ELEMENTS OF WORKSHOP TECHNOLOGY

The disadvantage with this type of tool post is that adjustment to height by tilting obviously alters all the cutting angles of the tool. The tool post is not also rigid enough for heavy work as only one clamping screw is used to clamp the tool.



**Figure Four bolt toolpost**

1. Tool, 2. Coil spring, 3. Strap, 4. Fulcrum block.

**Four bolt tool post :** The four bolt tool post is illustrated in Fig.3.12. The tool is held in position by two straps and four bolts. Loose coil springs are fitted to each bolt to keep the straps in place and greatly facilitate the setting up of the tools. Adjustment for tool height can be made by using parallel packing strips under the tools.

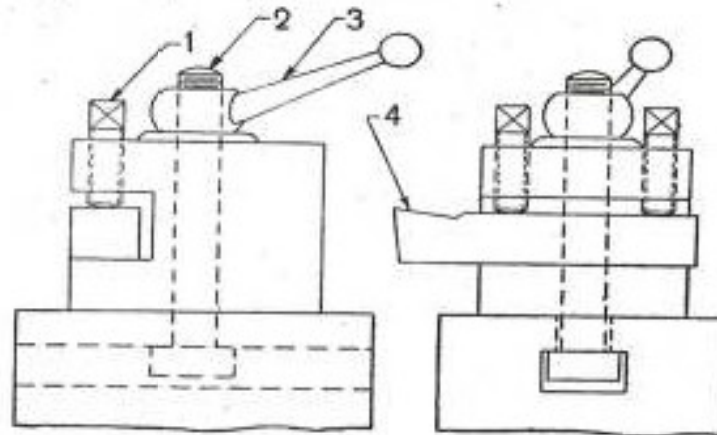

**Figure Open side toolpost**

1. Setscrew, 2. Central clamping bolt, 3. Clamping bolt handle, 4. Tool.



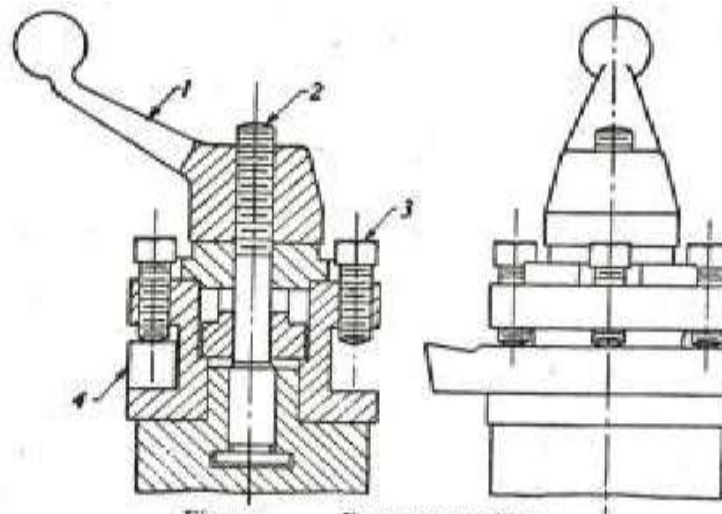

Figure Four way toolpost  
1. Clamping handle, 2. Central locking bolt, 3. Set screws, 4. Tool.

## 5. Apron:

The portion of the carriage which extends in front of lathe is called apron. It contains the gears, clutches. And levers for operating the carriage by hand or power feeds. The apron also contains friction clutches for automatic feed of a split nut or half nut which is closed over for cutting screw threads.

### **FEED MECHANISM:**

Feed is the distance the tool advances into the work piece through one revolution of head stock spindle a lathe tool has 3 types- longitudinal, cross and angular.

### **Longitudinal feed:**

When the tool moves parallel to the lathe axis, the movement is termed as longitudinal feed. It is used in cylindrical turning operations and is effected by movement of carriage.

### **Cross feed:**

When the tool moves parallel to the lathe axis, the movement is termed as cross feed. It is used in facing operation & affected by movement of cross slide.

## **Angular feed:**

When the tool moves at an angle to the lathe axis, it is termed as angular feed. It is used in taper turning and affected by movement of compound rest.

Angular feed is hand operated where cross feed & longitudinal feed can be both hand & power operated.

## **Third cutting mechanism:**

The rotation of the head screw is used to transverse the tool along were to produce screw thread. The half nut mechanism makes the carriage to engage or disengage or disengage with the lead screw. The two halves of the nut are connected in the cam slots in a circular disc by two pins. When the disc is rotated by a hand lever attached to it, the pins being guided in the cam slots serve to open or close the split nuts and thus engages or disengages with the lead screw.

The half nuts slide within the guide or frame. Closing the half nuts causes the carriage to move a fixed distance for each revolution of the spindle. The direction in which it moves depends upon the position of the feed reverse lever on the head stock. The split nut is used only for thread cutting and never for any other operation.

## **Lathe operation:**

Lathe operations are performed by following methods.

Operations which are performed in a lathe either by holding the work piece between centers or by a chuck:

1. **Straight turning**
2. **Shoulder turning**
3. **Chamfering**
4. **Thread cutting**
5. **Facing**
6. **Knurling**
7. **Filling**
8. **Taper turning**

9. Eccentric turning
10. Polishing
11. Grooving
12. Spinning
13. Spring winding
14. Forming

Operations which are performed by holding the work by a chuck or a face plate :

1. Drilling
2. Reaming
3. Boring
4. Counter boring
5. Taper boring
6. Internal thread cutting
7. Tapping
8. Under cutting
9. Parting off

Operations which are performed by using special attachments:

1. Grinding
2. Milling

## **Facing:**

Facing is the operation of for generation flat surface perpendicular to the rotational axis of spindle. The tool is fed to the axis of rotation of the work piece. A properly ground facing tool is used. A regular turning tool may also be used. a spindle speed is selected and the lathe is started. The tool is brought in to clean stock from the centre and fed out word by hand. Feed is given by cross slide.

## **Turning:**

# MANUFACTURING TECHNOLOGY

---

Turning in lathe is to remove excess material from the work piece to produce a cone-shaped or a cylindrical surface.

## **Straight turning:**

The work is turned straight when it is made to rotate about the lathe axis, and the tool is fed parallel to the lathe axis. It produces a cylindrical surface by removing excess metal from the work piece.

After facing the ends and drilling the centre, the job is carefully mounted between the centres using a lathe dog attached to the work piece, the bent tail of the dog fitting into the slot provided on the catihplat. A properly ground a right hand turning tool selected. The machine is started after the work piece and tool is properly set and correct spindle speed is determined.

The automatic feed is engaged to move the carriage to the desired length, then the feed is dis engaged and the carriage is brought back to the starting position. The process is repeated until the job is finally finished after two or three similar cuts.

There are two kinds of cuts in a machine shop work.

1. Roughing cut or rough turning.
2. Finishing cut or finish turning.

## **Rough turning:**

It is the process of removal of excess material from the work piece in a machine time by applying high rate of feed and heavy depth of cut. The doc is from 2 to 5 mm & feed rate is 0.3 to 1.5 mm per over.

## **Finish turning:**

It requires high cutting speed, small feed and a very small depth of cut to generate a smooth surface. The doc is from 0.5 to 1 mm & feed 0.1 to mm per rev.

## **Shoulder turning:**

When a work piece having different diameters is turned, the surface forming the step from one diameter to other is called shoulder turning

The principle of thread cutting is to produce a helical groove on a cylindrical or conical surface by feeding the tool longitudinal when the job is revolved between centres or by a chuck. The longitudinal feed should be equal to the pitch of the thread to be cut per revolution of the work piece.

The lead screw of lathe, through which saddle receives its traversing motion, has a definite pitch. A definite ratio between the longitudinal feed and rotation of the headstock spindle should therefore be found out. So that the relative speeds of rotation of the work and the lead screw will result in the cutting of a screw of the desired pitch.

This is affected by change gears arranged between the spindle and the lead screw or by the change gear mechanism or feed box used in a modern lathe where it provides a wider range of feed and the speed ratio can be easily and quickly changed

### **Taper Turning:**

A taper may be defined as a uniform increase or decrease in diameter of a piece of work mannered along its length.

In lathe taper turning means to produce a conical surface by gradual reduction in dia from a cylindrical work piece. The amount of taper is specified by the ratio of the difference in dia of taper to its length let it be denoted by  $k$  and termed as concity,

$$K = D-d/l$$

There are different methods for taper turning in lathe:

- 1. By a broad nose tool.**
- 2. By setting over the tail stock centre.**
- 3. By swivelling the compound rest**
- 4. By a taper turning attachment.**
- 5. By combining longitudinal feed & cross feed in a special lathe.**

## Taper turning in a form tool:

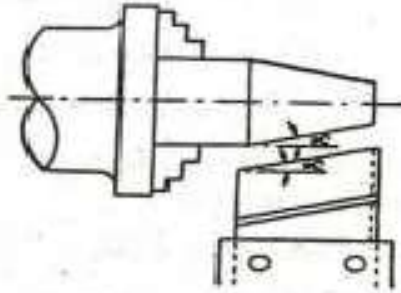
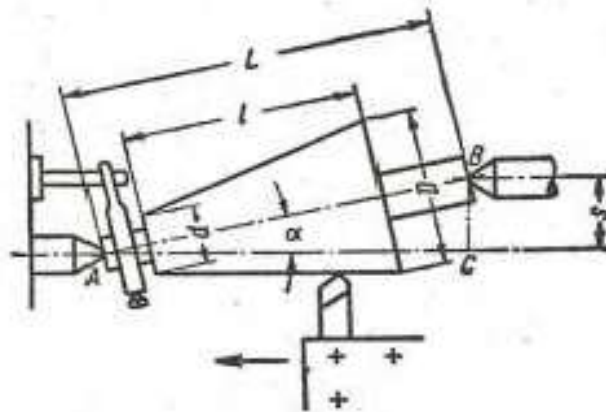

**Figure** Taper turning by a form tool

Abroad nose tool having straight cutting edge is set on to the work at half taper angle, and is feed straight into the work to generate a tapered surface. The half angle of taper will correspond to (90-SCEA) of the tool. The work is held in a chuck or clamped on a face plate.

It is used to turn short length of taper only.

## Taper turning by setting over the tailstock:



**Figure** Taper angle by setover method  
D. Large diameter of taper, d. Small diameter of taper,  
L. Length of the work, l. Length of the taper,  $\alpha$ . Half taper angle, S. Setover.

## MANUFACTURING TECHNOLOGY

---

The axis of rotation of the work piece is shifted at an angle to the lathe axis and the tool is fed parallel to the lathe axis. The angle at which the axis of rotation of the work piece is shifted is equal to half angle of the taper.

This is done by the tail stock is made to slide on its base or away from the operation by a set over screw.

This is used for turning small taper (not exceed  $8^{\circ}$ ) on long jobs.

### **By swivelling the compound rest:**

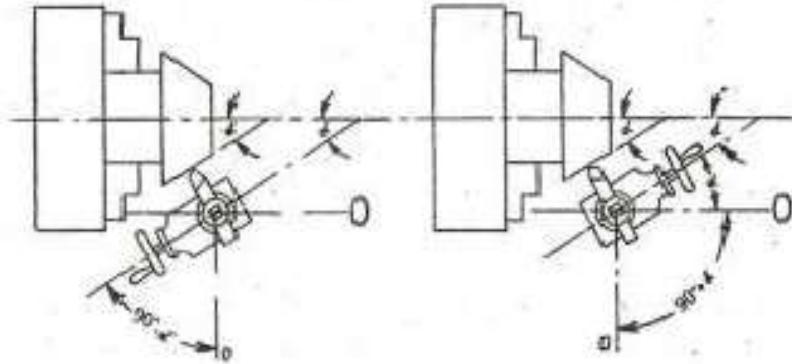

**Figure Taper turning by swivelling the compound rest.**

In this method the taper is formed by rotating the work piece on lathe axis and feeding the tool at an angle to the axis of rotation of work piece.

The tool mounted on the compound rest is attached to a circular base, graduated in degree, which may be swivelled and clamped at any desired angle the compound rest can be swivelled at  $45^{\circ}$  on either side of the lathe axis to turn a steep taper. The angle is determined by

## KNURLING:

Knurling is the process of embossing a diamond shaped pattern on the surface of a work piece. The purpose of knurling is to provided an effective gripping surface or a work piece to prevent it from slipping when operated by hand.

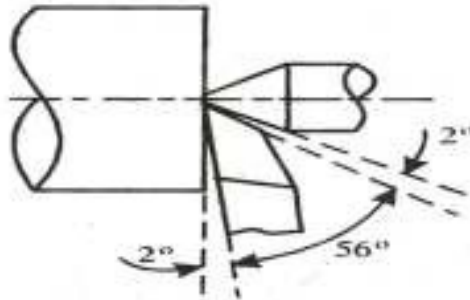

**Figure Facing operation**

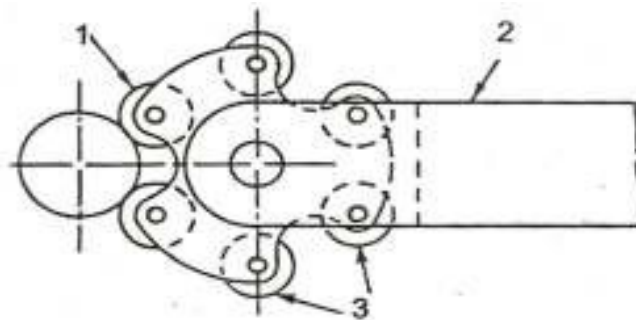

**Figure Revolving knurl holder**

1. First set of Knurl, 2. Knurl holder,
3. Second set of knurl.

The operation is perturbed by a special knurling tool which consists of 1 set of steel rollers in a holder. The tool is pressed against the revolving workpiece producing depressions in a regular pattern. On the surface of the work piece it is done at the speed  $\frac{1}{4}$  th of that of turning and plenty of oil is flowed on the tool and work piece feed varies from 1 to 2mm per rev.



## **Parting off:**

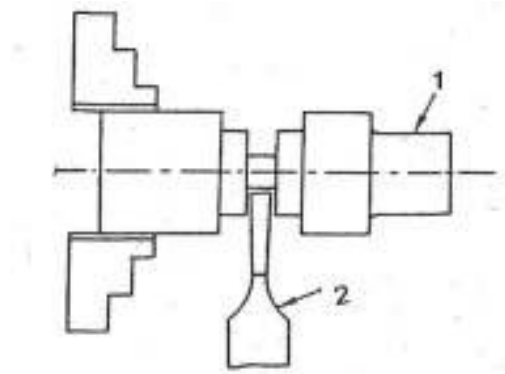

**Figure 3.69 Parting off operation**  
1. Work, 2. Parting off tool.

Parting off is the operation of cutting a work piece after it has been machined to the desired size & shape the job rotated on a chuck or face plate at half the speed that of turning and a narrow parting of tool is feed to the lathe axis by. Hand feed. The feed varies from 0.07 to 0.15 mm per rev. And depth at let ranges from 3 to 10 mm .

## **Internal machining:**

### **Drilling:**

Drilling is the operation of production a cylindrical hole in a work piece by rotating cutting edge of a cutter known as drill .

The work piece is revolved in a chuck or faceplate and the drill is held in the tailstock drill holder or in a drill chuck. Feeding is effected by the movement of the tail stock spindle (adopted for regular shaped work pieces)

The drill is held and driven by a drill chuck attached to the headstock spindle and the work is held against a pad supported by the tailstock spindle. Feeding is effected by the movement of the tailstock spindle (adopted for irregular shaped work pieces)

## **Boring:**

It is the operation of enlarging and truing a hole produced by drilling, punching, casting co-forging the

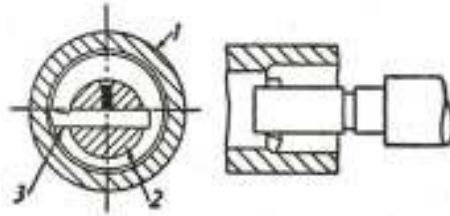

Figure Boring operation

The work is revolved in a chuck or a face plate and the tool which is flitted to the tool post is fed in to the work . One piece forged tool is used for boring small hole , whereas a boring bar with a tool bit attached to it is suitable for machining a large hole the doc is giver by the cross slide screw and the fade is feeder by the longitudinal travel of the carriage .

The work is clamped on the carriage and a boring bar holding the tool is supported between the centres made to revolute. Longitudinal movement of the carriage provides feeding movement and the doc is given by adjusting the position of the tool insert.

Internal thread to external forced cutting operation , the different being in the carriage provides feeding movement and the doc is given adjusting the position of the tool insert .

## **Internal thread cutting:**

It is similar to external thread cutting operation , the different being is the tool used . the tool is similar to boring tool with the cutting edges ground to the shape conforming to the type of thread to be cut the hole is first bored to the root dia of the thread for cutting metric to read the compound slide is swivelled 30° to words the headstock . the tool is fixed on the toolpost or on the boring bar after strive it at tught angle to the lathe axis

# MANUFACTURING TECHNOLOGY

---

, using a trove gauge the do is given by compound slide and the to read is finished in the usual manner.

## **Safety measures during machining:**

Some safety precautions should be needed while working on lathe.

- Before operating the machine, one should fully understand its operations controls and how to stop it.
- All gears and gear ends of the lathe should be properly guarded.
- Safety goggles are preferred to avoid damage to eyes by flying chips.
- Avoid wearing rings, bracelet or watch.
- Machine should not be left running and operator should be alert during a job.
- Before starting a lathe spindle by power, spindle should be rotated by one revolution by hand to make it sure that no fouling is there.
- Safe distance from revolving chuck should be maintained.
- Tools and instruments should not be placed over lathe bed.
- Sliding parts of the lathe should be cleaned and lubricated periodically.
- Chips should never be removed by hand. It can be removed by brush.
- Before starting the machine, the work should be clamped properly.
- Before moving the carriage, the carriage clamping screw should be unlocked.
- On hearing unusual noise, machine should be stopped immediately and should not be operated till the fault is clear.

# MANUFACTURING TECHNOLOGY

## Capstan & Turret lathes:

A capstan or a turret lathe is a production lathe used to manufacture any number of identical pieces in the minimum time. The main feature is the six sided block mounted on one end of the bed replacing the normal tailstock six tools can be mounted at on cross slide two tool posts are mounted, one in the front and the other in the rear. Each one can hold four tools .Thus the total carrying capacity is a maximum 14 tools

## Difference between CAPSTAN & TURRET and an ENGINE LATHE

CAPSTAN & TURRET	ENGINE LATHE
1. The head stock possesses wider range of speeds and in heavier in construction it require 15 hp power to drive the spindle.	1. It requires 3hp to drive the spindle.
2. The tool post mounted or the cross slide is a four way & a rear tool post is mounted on the rear side which also holds 4 tools.	2. In engine lathe one tool can be mounted at one time for different operation.
3. In turret lathe, the tail stock is replaced by a turret which is a hexagonal block which contains 6 tools on each face.	3. It can accommodate one tool of limited size.
4. The feed movement of each tool set on square or hexagonal turret is regularity by stops & feed strips.	4. The feed movement is given by hand.
5. Combination cuts can be taken by mounted two or more tools on the same face of the turret.	5. Combination cuts cannot be done.
6. The labour cost is less.	6. Labour cost is more.

## MANUFACTURING TECHNOLOGY

7. The threads are cut by die heads & taps.	7. The threads are cut by lead screws Centre lathe is suitable for odd jobs having different shapes & sizes.
8. Turret lathes are suitable for producing large no. Of identical pieces.	8. The threads are cut by lead screws.

### **Difference between capstan & turret lathe:**

Capstan lathe	Turret lathe
<ol style="list-style-type: none"> <li>1. Its turret head is mounted in slide, which moves on the guide ways produced on the saddle.</li> <li>2. For feeding the tool to the work, the saddle is fixed at convenient distance from the work.</li> <li>3. It is suitable for smaller size &amp; lighter jobs. It is not suitable for heavy cutting condition.</li> <li>4. It is suitable to work for smaller bar upto 60 mm dia.</li> <li>5. The turret head may hexagonal or circular.</li> <li>6. It is smaller in size compound to turret lathe.</li> <li>7. The tool traverse is faster and offer less fatigue to the hands of the operator.</li> </ol>	<ol style="list-style-type: none"> <li>1. Its turret to head is mounted directly on the saddle.</li> <li>2. For feeding the tool to the work, the entire saddle unit is moved.</li> <li>3. It is suitable for long and heavy work and severe cutting condition.\</li> <li>4. It is used to work for large size bar upto 200mm dia.</li> <li>5. Turret head is hexagonal.</li> <li>6. It is large in size as compared to capstan lathe.</li> <li>7. The tool feeding is relatively slower and provide more fatigue to operator hands.</li> </ol>

## The capstan or ram type lathe:

The capstan or ram type turret or capstan lathe carries a hexagonal turret on ram or short slide, the ram slide longitudinally on a saddle on bed ways. the feeding movement is obtained when the ram moves from left to right and when the ram moved backward the turret indexes automatically and the tool mounted on the next face comes into operation. This type of machine is lighter in construction and is suitable for machinery bar of small diameter.

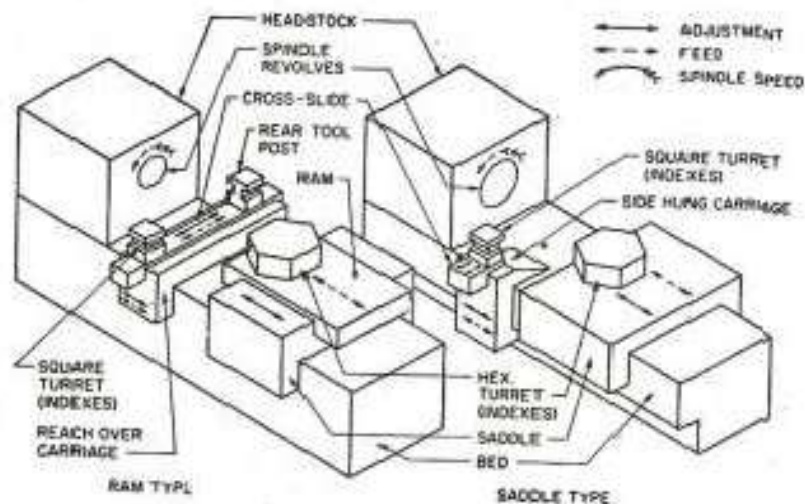

**Figure** Ram type (capstan) and saddle type (turret) lathes  
(Reproduced from Doyle *et al*)

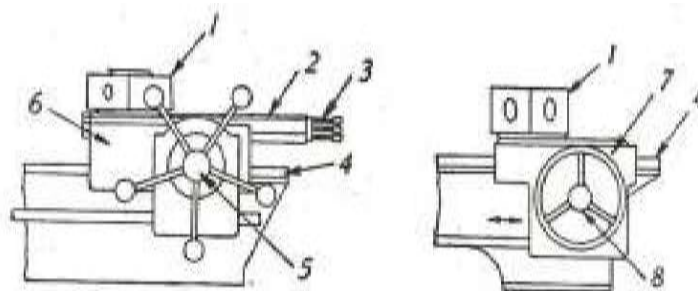
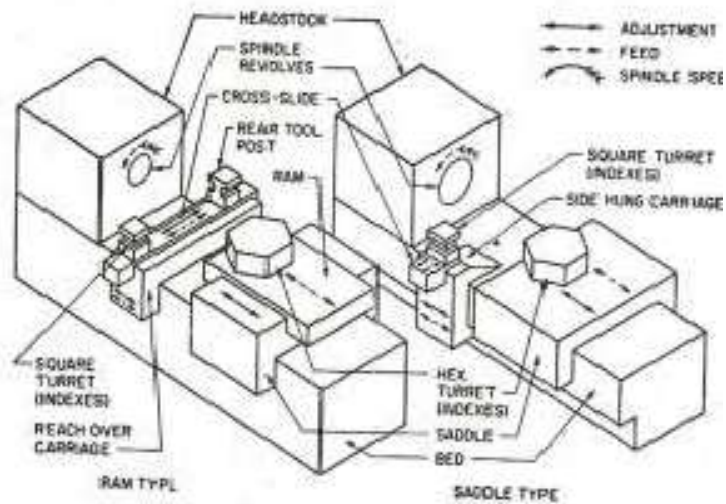

**Figure** Capstan and turret lathe to show their difference  
1. Hexagonal turret, 2. Auxiliary slide, 3. Feed stop rod, 4. Lathe bed, 5. Handwheel for auxiliary slide, 6. Saddle, 7. Turret saddle, 8. Handwheel for saddle.

## The turret or saddle type lathe

The hexagonal turret is mounted directly on the saddle and the whole unit moves back and forth on the bed ways to apply feed. The machine can accommodate longer work pieces than that in a capstan lathe. It is heavier in construction and for larger bar work and chucking work.

186 ELEMENTS OF WORKSHOP TECHNOLOGY



## Multiple Tool holder.

Both capstan and turret lathe carry a multiple holding device called capstan head in capstan lathe and turret head in case of turret lathe. The capstan head usually circular carrying six slots. It can be mounted either its axis vertical or at an inclination. The turret head can be square, hexagonal or octagonal in shape having one hole on each face. The hexagonal type is more commonly used. It is always mounted with its axis vertical except in case of vertical turret where the axis of rotation of the turret head is horizontal.

## Parts of capstan and turret lathe:

### Bed:

The bed is longer box like casing provided with accurate guide ways on which the carriage and turret slid are mounted. It is designed to ensure strength, rigidity and permanency of alignment under heavy duty services.

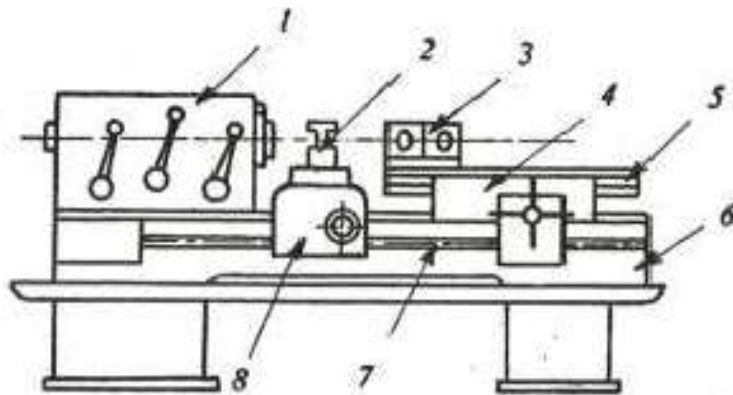

**Figure 4.3. Capstan lathe parts**

1. Headstock, 2. Cross-slide toolpost, 3. Hexagonal turret, 4. Saddle for auxiliary slide, 5. Auxiliary slide, 6. Lathe bed, 7. Feed rod, 8. Saddle for cross-slide.

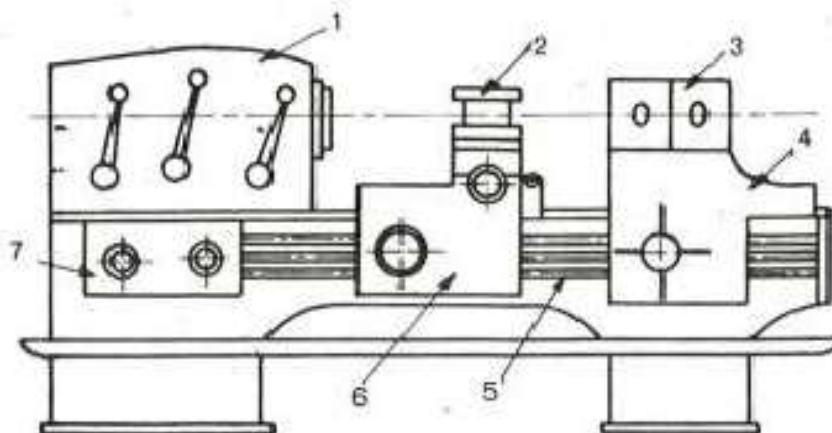

**Figure 4.4 Turret lathe parts**

1. Headstock, 2. Cross-slide toolpost, 3. Hexagonal turret, 4. Turret saddle, 5. Feed rod, 6. Saddle for cross-slide.



# MANUFACTURING TECHNOLOGY

---

## **Headstock:**

It is similar to engine lathe in construction. It is larger & heavier in construction and wider range of speeds speed may range from 30 to 2000rpm two types of headstocks.

- a) Electric head - variable speed motor is mounted.
- b) All geared heads - wider range of speeds

The spindle is hollow and bar stock can be fed through a collar chuck .

## **Gross slide & saddle:**

There are two types of slides used in turret lathe

- > Conventional type
- > Slide hunk type

The conventional type of Carriage Bridge the gap between the front and rear bed ways

The slide hunk type carriage is generally fitted with heavy duty turret lathe. Large diameter of work pieces can be swing over bed. The longitudinal movement of each tool may be regulated by using stop bars or shafts set against the stop fitted on the bed and carriage. The stops are set so the each tool will feed into the work to desired length the stop bars are indexed by hand

## **The turret saddle and auxiliary slide :-**

The turret saddle bridges the gap between two bed ways. The hexagonal turret is mounted on the auxiliary slide. In turret lathe, the turret is directly mounted on the top of the saddle.

The turret is a hexagonal shaped tool holder intended for six or more tools. The centre line of each hole coincides with the axis of the lathe. Six stop bars are mounted on the saddle which restricts the movement of each tool mounted on each face of turret to be fed predetermined amount. After one operation the turret is brought backward from the spindle nose the turret indexes automatically.

## Capstan and turret lathe mechanism:-

### Turret head indexing mechanism:-

This is an inverted plan of turret assembly. The turret is mounted on the spindle. The index plate, the bevel gear and an indexing ratchet are keyed to the spindle. The plunger fitted within the housing and mounted on the saddle locks the index plate by spring pressure and prevents any rotary movement of the turret as the tool feeds into the work.

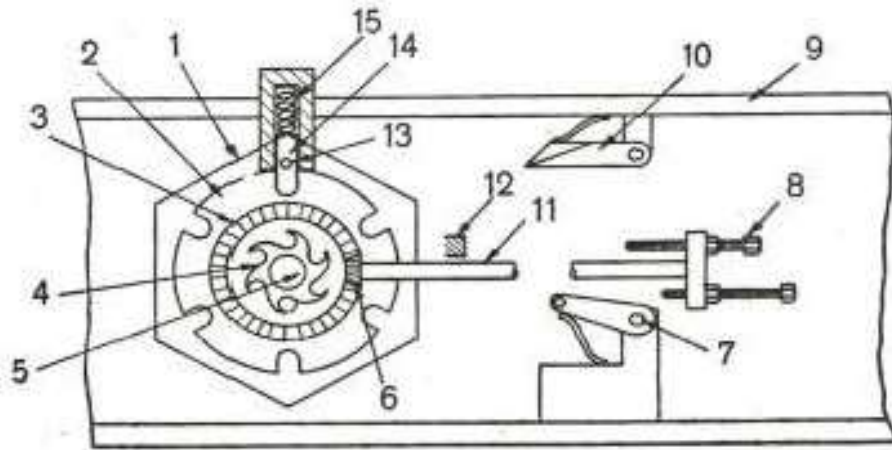

**Figure 4.5 Turret indexing mechanism**

1. Hexagonal turret, 2. Index plate, 3. Beveled gear, 4. Indexing ratchet, 5. Turret spindle, 6. Beveled pinion, 7. Indexing pawl, 8. Screw stop rods, 9. Lathe bed, 10. Plunger actuating cam, 11. Pinion shaft, 12. Stop, 13. Plunger pin, 14. Plunger, 15. Plunger spring.

A pin is fitted on the plunger projects out of the housing. An actuating cam and the indexing pawl are attached to the lathe bed at desired positions. Both the cam and the pawl are spring loaded. As the turret reaches the backward position, the attaching cam lifts the plunger out of the groove in the index plate due to the riding of the pin on the bevelled surface of the cam and thus unlocks the index plate.

The spring loaded pawl which by this time engages with a groove of ratchet plate, causes the ratchet to rotate as the turret head moves backward.

## MANUFACTURING TECHNOLOGY

---

When the index plate or turret rotates through one sixth of revolution, the pin and the plunger drops out of the cam and the plunger locks the index plate at the next groove.

The turret is thus indexed by one sixth of revolutions and again backed into the next position automatically. The turret holds the next tool is now fed forward and the pawl is released from the ratchet plate by the spring pressure.

The bevel opinion meshes with the bevel gear mounted on the turret spindle. The extension of the pinion shaft carries a plate holding six adjustable stop rods. As the turret rotates through one sixth of the revolution, the bevel gear causes the plate to rotate.

The ratio of the teeth between the pinion and the gear are so chosen that when the tool mounted on the face of the turret is indexed to bring it to the cutting position, the particular stop rod for controlling the longitudinal travelling of the tool is aligned with the stop.

The setting of the stop rods for limiting the feed of each operation may be adjusted by unscrewing the lock nuts and rotating the stop rods on the plate. Thus, six stop rods may be adjusted for controlling the longitudinal travel of tools mounted on six faces of the turret.

### **Bar feeding mechanism:-**

On the capstan and turret lathes, some arrangements is need to be feed the bar stock through the collet or chuck after each finished work piece is parted off. Bar may be fed by hand also but has a safety measure one has to stop the machines first for every feeding of bar. It also wastes lot of time.

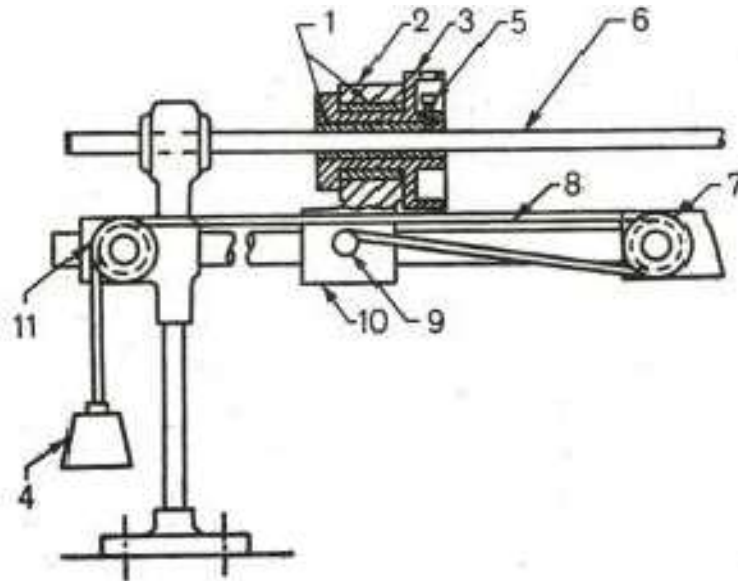

**Figure 4.6 Bar feeding mechanism**

1. Chuck bush, 2. Sliding bracket body, 3. Bar chuck, 4. Weight, 5. Bar chuck set screw, 6. Bar, 7, 11, Pulley, 8. Chain, 9. Pin on the sliding bracket, 10. Sliding bracket

In this method the bar is push forward as soon as it release from the collect without stopping the lathe.

A bar feeding mechanism is fitted with a capstan lathe is the back side of lathe. Bar is fed against the rotating sleeve and the collet chuck. The bar stock passes through the spindle of the collet chuck. One end of the rope is connected with a sleeve and the other end is attached with a weight.

Under the action of the weight, the bar moves towards the head stock. At the end of the parting off operation on the job. It is needed to feed the new length of the bar. As soon as the collet is opened by operating the Colet control lever, the bar is release and is automatically rushes out of the collet and strike with the bar stop.

The bar stop mounted on the capstan head for the purpose of getting the required bar length projecting out of the colet. The colet lever is again operated to close the collet and hold the bar tightly.

# MANUFACTURING TECHNOLOGY

## **Tooling layout:**

The tool layout for a job constitute the predetermined plan for the order and method of machining operation necessary to produce it. For preparation of the layout, it is necessary to have a finished drawing of the part to be produce. The tool layout consists of two steps: preparation of operation sheet.

Sketching the plan showing various tolls fitted into the turrent faces and the cross slides, in proper sequence.

## **Production of hexagonal bolts:-**

Operation no.	description of operation	tool position	tools
1	Hold in collet	1 <sup>st</sup> turret position	Bar stop
2	Turn to 16 mm dia	2 <sup>nd</sup> turret position	Roller steady bar turning tool
3	Form end of the bolt	3 <sup>rd</sup> turret position	Roller steady bar ending tool
4	Screw 16 mm	4 <sup>th</sup> turret position	Self opening die head with chasers for 16 mm
5	Chamfer	Front cross slide tool post	Chamfering tool
6	Parting off	Rear tool post	Parting off tool

## **For bush:-**

Sl no	Sequence of operation	Machine shop	Tools / gauges
1	Fixed end 2mm deep	Turret lathe position1 (rear slide)	Bar ending tool
2	Feed out bar stop	Position 2	Bar stop
3	Stop for drilling	Position 3	Centre drill
4	Drill hole 10 mm	Position 4	Drill 10 mm dia,

## MANUFACTURING TECHNOLOGY

	dia, and rough turn 16.5dia×36 mm		rough turning tool
5	Finish turn to 16.10 mm dia, bore 11.5 dia ×36 mm and chamfer 0.3×45°	Position 5	Finish turn tool, chamfering tool and boring tool
3	Rough ream 11.8 mm dia×36 mm	Position 6	Reaming toll rough
7	Finish ream 11.8mm dia × 36 mm	Position 7	Reaming tool finish
8	Cut off to 31 mm length	Position 8	Parting off tool
9	Chamfer other end 0.3×45°	Upright drill	Chamfering tool
10	Drill oil hole	Upright drill	Drill 2mm
11	Cut oil grooves	Special machine	Groove cutter
12	Grind to 16 mm dia	Cylindrical grinder	Finish grading wheel
13	inspect	Inspection department	Limit gauges

1. Feed the bar stock to stop
2. Turn 14 mm dia with box tool
3. Turn 14.28 mm dia with box tool
4. Round end with roller steady ending tool
5. Centre with centre drill
6. Cut threads with die head
7. Form 17 mm dia and chamfer with tool from front square slide
8. Part off with cut of tool in rear tool

## Chapter-4

# Shaper

### Shaper:-

The shaper is a reciprocating type of machine tool intended to produce flat surfaces. The surface may be horizontal, vertical or inclined

### Working principle:-

The job is fixed rigidly in a suitable vice or directly clamped on the machine table. The tool is held in the tool post mounted on the ram of the machine. This ram reciprocates to and fro, and in doing so, makes the tool to cut the material in the forward stroke. No cutting takes place during the return stroke of the ram. It is called idle stroke. The job is given an intended feed, in a direction normal to the line of action of the cutting tool.

## **Types of shapers:-**

1. According to the type of mechanism used for giving reciprocating motion to the ram.
  - a. Crank type
  - b. Geared type
  - c. Hydraulic type
2. According to the position and travel of ram .
  - a. Horizontal type
  - b. Vertical type
  - c. Travelling head type
3. According to the type of design of the table
  - a. Standard shaper
  - b. Universal shaper
4. According to the type of cutting stroke
  - a. Push type
  - b. Draw type

## **Specification of shaper:-**

1. Maximum length of stroke(175-900mm)
2. Maximum horizontal travel of table
3. Maximum vertical travel of table
4. Maximum distance from table to ram
5. Tool box, vertical adjustment
6. Length and width of the table
7. Numbers and range speeds available
8. Numbers and range feeds available
9. Horse power and speed of driving motor
10. Weight of the machine and floor space required



# MANUFACTURING TECHNOLOGY

---

## **Crank shaper:-**

This is a most common type of shaper. It uses a crank mechanism to change circular motion of a large bull gear into reciprocating motion of the ram

## **Geared type:-**

The reciprocating motion is effected by means of rack and pinion

## **Hydraulic shaper:-**

The reciprocating motion is obtained by hydraulic power.

## **Horizontal shaper:-**

The ram reciprocates in a horizontal axis

## **Vertical axis:-**

The ram reciprocates in a vertical axis

## **Travelling head shaper:-**

The ram reciprocates and moves crosswise to give required feed

## **Standard or plain shaper:-**

The table has two movements, vertical and horizontal to give the feed

## **Universal shaper:-**

In addition of the two movements, the table can be swivelled about on axis parallel to the ram ways.

## **Push type:-**

The most general type of shaper used in common practice . the metal is removed when the ram moves away from the column

## **Draw type shaper :-**

The metal is removed when the ram moves towards the column of the machine, draws the work towards the machine. The tool set is reversed direction to that of a standard shaper.

## DIFFERENT PARTS OF A SHAPER:-

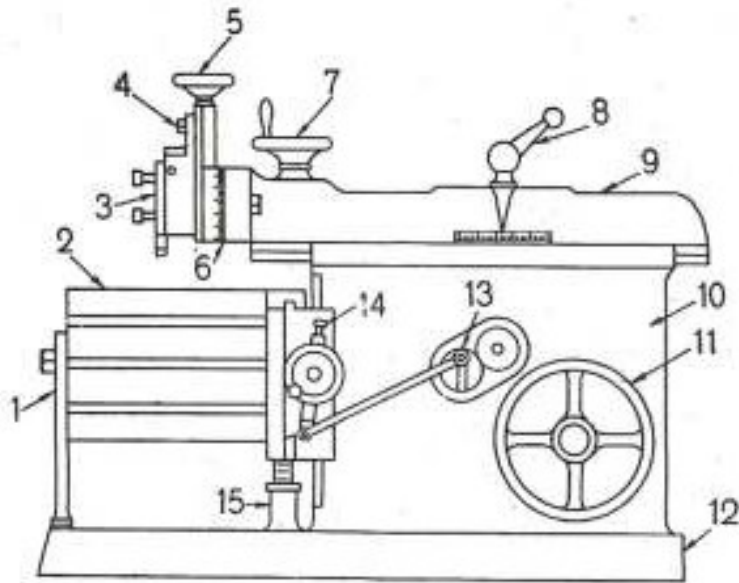

**Figure 7.1 Parts of a standard shaper**

1. Table support, 2. Table, 3. Clapper box, 4. Apron clamping bolts, 5. Downfeed hand wheel, 6. Swivel base degree graduations, 7. Position of stroke adjustment handwheel, 8. Ram block locking handle, 9. Ram, 10. Column, 11. Driving pulley, 12. Base, 13. Feed disc, 14. Pawl mechanism, 15. Elevating screw.

## BASE:-

The base provides stability for the shaper as it supports all other equipments present as well as absorb the forces coming due to the cutting . it is made of cast iron and have a necessary arrangements of bolts so that it can be bolted to the factory floor.

## Column(housing):-

The column of the shaper is a hollow casting and is mounted on the base. It houses the ram driving mechanism. For the ram and table, on the top of the column, necessary guide ways are provided for the linear movement of the ram and the front vertical face is for cross rail.

# MANUFACTURING TECHNOLOGY

---

## **Cross rail:-**

The cross rail is mounted on the front vertical guideways of the column. It has two parallel guide ways on its top vertical plane that are perpendicular to the ram axis. The table may be raised or lowered to accommodate different sizes of job by rotating elevating screw.

## **Saddle:-**

The saddle is mounted on the cross rail which holds the table . on its top crosswise movement of the table is powered by rotating cross feed screw.

## **Table:-**

The work table of a shaper is fastened to the front of the column. The table is provided T-slots for mounting the work pieces. The table can be moved up and down and crosswise by cross rail and saddle. Jobs can be held by vice.

## **Ram:-**

The ram is a reciprocating member of the shaper. It is semicylindrical in form and heavily ribbed inside to make more rigid. It slides on the guideways of the column. A single point cutting tool is fastened in the tool post.

## **Tool head:-**

The single point cutting tool is held in the tool post. The tool head holds the tool provides vertical and angular feed movement and allows the tool to have an automatic relief during return stroke. The vertical side of the tool head has a swivel base which is held on a circular seat on the ram.

The swivel base is graduated in degrees so that the vertical slide may be set perpendicular to the work surface at any desired angle. By rotating the down feed screw handle, the vertical slide carrying the tool executes down feed or angular feed movement while machining vertical or angular surface.

The amount of feed or depth of cut may be adjusted by a micrometer dial on the top of the down feed screw. Apron consisting of clapper box,

# MANUFACTURING TECHNOLOGY

---

clapper block and tool post is clamped upon the vertical slide by a screw. By releasing the clamping screw, the apron may be swivelled upon the apron swivel pin either towards left or towards right w.r.t the vertical slide. This arrangement is necessary to provide relief to the tool while making vertical or angular cuts.

The two vertical walls on the apron called clapper box houses the clapper block which is connected to it by means of a hinge pin. The tool post is mounted upon the clapper block.

On the forward cutting stroke the clapper block fits securely to the clapper box to make a rigid tool support on the return stroke a slight frictional drag of the tool on the work lifts the block out of the clapper box a sufficient amount preventing the tool cutting edge from dragging and consequent wear. The work surface is also prevented from any damage due to dragging.

## **Shaper mechanism:-**

The metal is removed in the forward cutting stroke, while the return stroke no metal is removed during this period.

To reduce the total machining time it is necessary to reduce time taken by the return stroke. The shaper mechanism should be so designed that it can allow the ram holding the tool to move at comparatively slower speed during the forward cutting stroke and during the return stroke the ram move faster rate to reduce the idle return time. The mechanism is called quick return mechanism.

- 1. Crank and slotted mechanism**
- 2. Whitworth quick return mechanism**
- 3. Hydraulic shaper mechanism**

## **Crank and slotted link mechanism:-**

The motion or power is transmitted to the bull gear through a pinion which receives its motion from an individual motor or overhead line shaft through speed control mechanism. Speed can be changed by shifting gears.

A radial slide is bolted to the centre of the bull gear, carries a sliding block into which the crank pin is fitted. rotation of the bull gear causes the

## MANUFACTURING TECHNOLOGY

---

crank pin to rotate at a uniform speed. Sliding block which is invented on the crank pin is fitted within the slotted link. The slotted link is pivoted at its bottom end attached to the frame of the column. The upper end is forked and connected to the ram block by a pin.

As bull gear rotates causes the crank pin to rotate, the sliding block fastened to the crank pin will rotate on the crank pin circle, and at same time will move up and down in the slot giving a rocking movement which is communicated to the ram. The rotary motion of the bull gear converted to reciprocating movement of the ram.

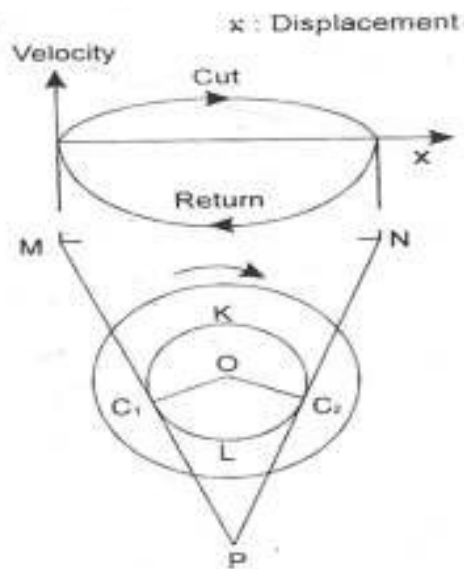

**Figure 7.4 Principle of quick return mechanism**

When the link is in the position PM, ram will be at the extreme backward of its stroke.

When at PN – extreme forward position PM

& PN are tangent to the crank pin circle.

$C_1C_2$  □ forward cutting stroke

$C_2C_1$  □ return stroke

# MANUFACTURING TECHNOLOGY

---

It is clear that the angle made by the forward stroke > return stroke.  
The angular velocity is constant  $\square$  rotated by speed metre and the crank rotates at uniform speed.

Generally varies 2:1 and practical 3:1

### Whitworth quick return mechanism:-

A bull gear is mounted on a large fixed pin upon which it is free to rotate. The crank plate is pivoted eccentrically upon the fixed pin at 5. fitted on the face of the bull gear is the crank pin 2 on top of which sliding block is mounted. Sliding block fits into the slot provided on the crank plate. a connecting rod connects the crank plate by a pin and the ram by a pin.

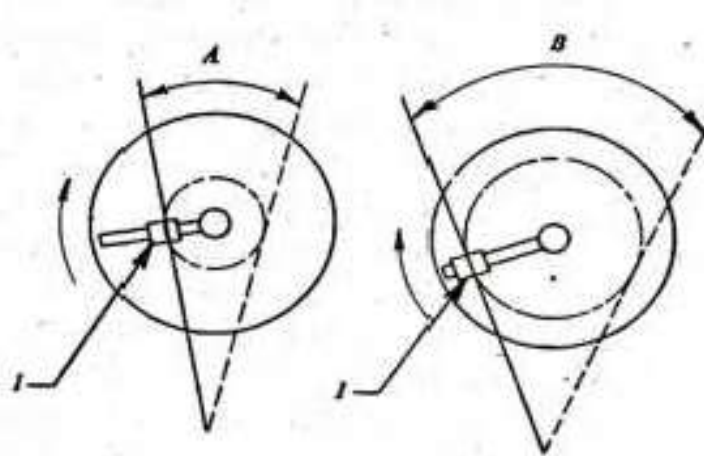

**Figure Stroke length adjustment**  
1. Position of crankpin, A. Short stroke length, B. Long stroke length.

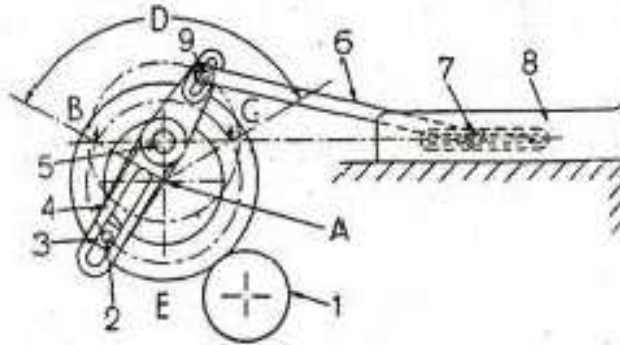

**Figure Whitworth quick return mechanism**

1. Driving pinion, 2. Crank pin, 3. Sliding block, 4. Crank plate, 5. Pivot for crank plate, 6. Connecting rod, 7. Connecting pin for ram, 8. Ram, 9. Pin, A. Fixed pin.

When the bull gear will rotate at constant speed the crank pin with the sliding block will rotate on a crank pin with the sliding block will rotate on a crank circle of radius  $A_2$  and the sliding block will cause the crank plate to rotate about the point 5 with a variable angular velocity.

Pin fitted on the other end of the crank plate will rotate in a circle and the rotary motion of the pin will be converted into reciprocating movement in the ram. Similar to crank and connecting rod mechanism. The axis of reciprocating of the ram passes through the pin and normal to the line  $A_3$ .

When the pin cutting stroke is at position C □ extreme backward position

When the pin cutting stroke is at position B □ forward position

CB = cutting stroke (backward to forward)

BC = return stroke (forward to backward)

As angular velocity of the crank pin is uniform for the time taken i.e,

$$\frac{\text{Time of cutting stroke}}{\text{Time of return stroke}} = \frac{\beta}{\alpha} = \frac{\beta}{360^\circ - \beta} \quad \text{or} \quad \frac{360^\circ - \alpha}{\alpha}$$

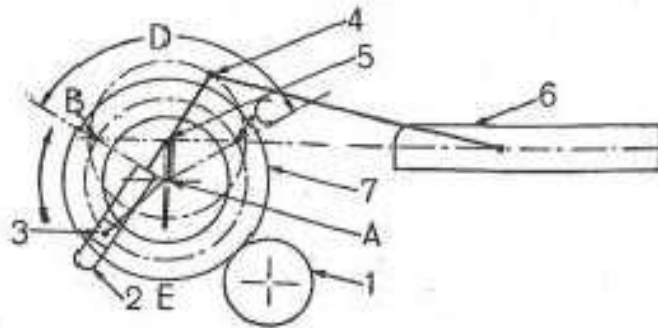

**Figure 7.8 Line diagram of quick return mechanism**

1. Driving pinion, 2. Crank plate, 3. Sliding block, 4. Crank pin for connecting rod, 5. Pivot for crank plate, 6. Ram, 7. Bull gear, A. Fixed pin.

## Hydraulic shaper mechanism:-

In a hydraulic shaper the ram is moved forward and backward by a piston moving in a cylinder placed under the ram.

The machine consists of a constant discharge oil pump, a valve chamber, a cylinder and a piston. The piston rod is bolted to the ram body. The oil under a high pressure is pumped from the reservoir and is made to pass through the valve chamber to the right side of the oil cylinder exerting pressure on the piston. This causes the ram connected to the piston to perform forward stroke ward by a piston moving in a cylinder placed under the ram.



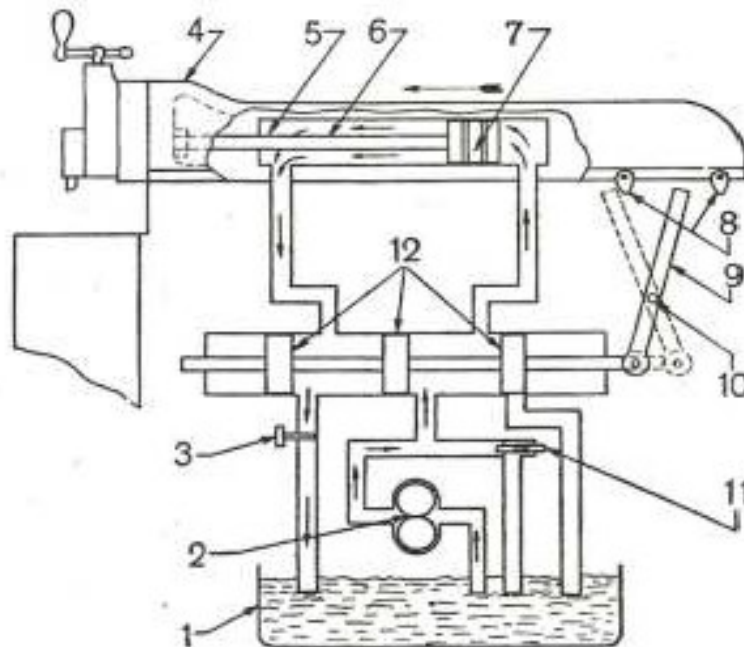

**Figure 7.9 Hydraulic shaper mechanism**

1. Oil reservoir, 2. Oil pump, 3. Throttle valve, 4. Ram, 5. Cylinder, 6. Piston rod, 7. Piston, 8. Reversing dog, 9. Reversing lever, 10. Reversing lever pivot, 11. Relief valve, 12. Valves.

The machine consists of a constant discharge oil pump, a valve chamber, a cylinder and a piston. The piston rod is bolted to the ram body. The oil under a high pressure is pumped from the reservoir and is made to pass through the valve chamber to the right side of the oil cylinder exerting pressure on the piston.

This causes the ram connected to the piston to perform forward stroke, and any oil present on the left side of cylinder is discharged to the reservoir through the throttle valve. At the extreme of forward stroke, the shaper dog hits against the reversing lever causing the valves to alter their positions within the valve chamber oil under high pressure is now opened to the left side of the piston causing the ram to perform return stroke.

Oil present on the right side of the piston is now discharged to the reservoir. At the end of the return stroke another shaper dog hits against the reversing lever altering the direction of stroke of the piston and thus the cycle is repeated.

## MANUFACTURING TECHNOLOGY

---

The quick return motion is effected due to the difference in stroke volume of the cylinder at both ends, the left hand being smaller due to the presence of piston rod. As the pump is a constant discharge one, within a fixed period, the same amount of oil will be pumped into right or left hand side of the cylinder.

This will mean that the some amount of oil will be packed within a smaller stroke volume causing the oil pressure to rise automatically and increasing the speed during the return stroke.

### **Automatic cross feed mechanism:-**

In a shaper both down feed and cross feed can be obtained. Vertical or bevel surfaces are produced by rotating the down feed screw of the tool head by hand. Cross feed movement is used to machine a flat horizontal surface. This is done by rotating the cross feed screw by hand or power.

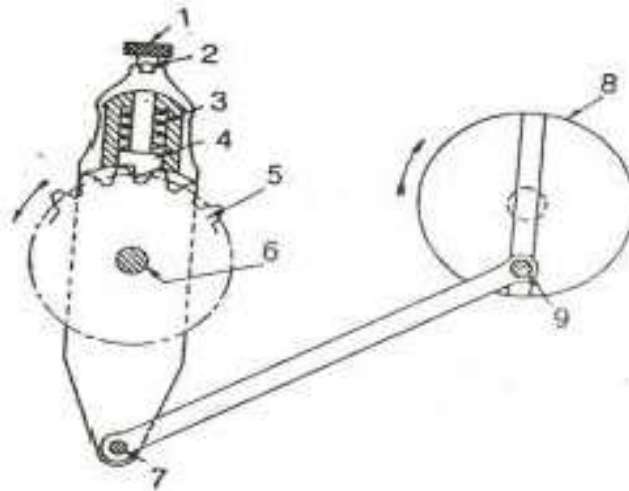

**Figure 7.10 Automatic feed mechanism of a shaper**

1. Knob, 2. Pin, 3. Helical spring, 4. Pawl,
5. Ratchet wheel, 6. Rocker arm fulcrum,
7. Rocker arm connecting pin, 8. Driving disc, 9. Crank pin.

## MANUFACTURING TECHNOLOGY

---

Rotation of the cross feed screw causes the table to move sideways at the end of each return stroke to bring the uncut surface of the work. This is done by automatic cross feed mechanism of shaper.

The rotation of the bull gear causes the driving disc to rotate in a particular direction. The driving disc is T- slotted and position of the crank attached to the connecting rod may be altered to give different throw of eccentricity. The other end of the connecting rod is attached to the rocking arm by a pin. The rocking arm is fulcrum at the centre of the ratchet wheel. The ratchet wheel is keyed to the cross feed screw. The rocking arm houses a spring loaded pawl which is straight on one side and bevel on the other side..

As the driving disc rotates, the connecting rod starts reciprocating and the rocking arm rocks on the fulcrum. When the driving disc rotates through half of the revolution in the clockwise direction, top part of the rocking arm moves in clockwise direction and the pawl being slant on one side slips over the teeth of the ratchet wheel imparting it no movement.

As the driving disc rotates through the other half, the top of the rocking arm now moves in the anticlockwise direction and the straight side of the pawl engages with the teeth of the ratchet wheel causing the wheel to move in anticlockwise direction only. As the driving disc is connected to the bull gear the table feed movement is effected when the bull gear or driving disc rotates through half of the revolution i.e, during return stroke only.

Rotation through other half imparts no feed movements. To reverse the direction of rotation of ratchet wheel and feed, a knob on the top of the pawl after removing the pin is rotated through  $180^\circ$ .

The movement of feed may be altered by shifting the position of crank pin w.r.t the centre. Greater the through the eccentricity more will be the rocking movements of the arm and the pawl will pass through three or four teeth on the ratchet wheel at a time imparting greater feed movement.

## Chapter-5

### Planing Machine

The planer like a shaper is a machine tool to produce plane and flat surfaces by a single point cutting tool

#### **Difference between shaper & planer**

The work is stationary; the tool along with ram reciprocates against the work.

The work which is supported on the table reciprocates and the tool is stationary.

# MANUFACTURING TECHNOLOGY

---

## **Principal parts of a planner:**

### **BED:**

- The bed of a planner is a box like casting cross ribs.
- It is a very large in size and heavy in weight and it supports the column and all other moving parts of the machine.
- The guides ways are provided on the bed for the movement of the table.
- The hollow space within the box like structure of the bed home the driving mechanism for the table.

### **Table:**

- The table supports the job and reciprocates along the ways of the bed.
- The planner table is heavy rectangular casting and is made of cast iron.
- The top face of the table is accurately finished in order to hold the job correctly.
- The top face of the table is 'T' slotted for clamping the job and job holding devices.
- At each end of the table or hollow space is left for collecti9ng chips.
- A groove is cut on the side of the table for clamping planner revising dugs at different position.

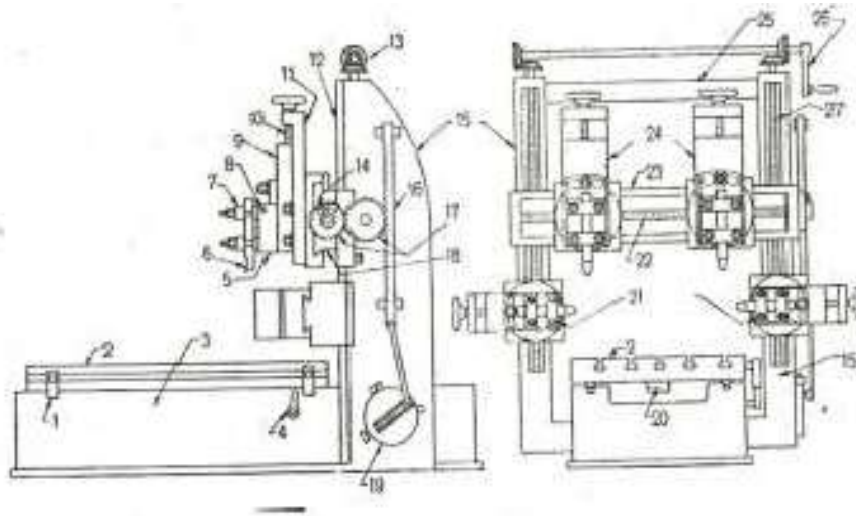

**Figure 8.1 Standard double housing planer**

1. Trip dog, 2. Table, 3. Bed, 4. Reversing lever, 5. Clapper box, 6. Tool, 7. Tool Post, 8. Hinge pin, 9. Vertical slide, 10. Downfeed screw, 11. Slide, 12. Guideways on column face, 13. Feed screw for elevating crossrail, 14. Pawl, 15. Column or housing, 16. Rack, 17. Feed gears, 18. Saddle, 19. Feed disc, 20. Table rack, 21. Slide toolhead, 22. Feed screw, 23. Crossrail, 24. Vertical toolheads, 25. Crossmember, 26. Crossrail, elevating handle, 27. Cross elevating screw.

## **Column:**

- It is a rigid vertical box like structure.
- The front face of each housing is accurately machines to provide guide ways on which the crossrail may be slipped up and down for accommodating the different suitable heights job.
- The housing is enclosed with vertical elevating screw and cross feed screws for tool heads and counter balanced the weight of the cross rail.

## **CROSS RAIL:**

- It is a rigid box like casting connecting the two housings.
- The cross rail can be raised or lowered on the face of the housing and can be clamped at any desired position.
- The cross rail when clamped should remain parallel to the top surface of the table.

# MANUFACTURING TECHNOLOGY

---

- › The two elevating screws in two the housing are rotated by an equal horizontal any in position.
- › The two tool heads are mounted upon the cross rail.
- › The cross rail has screws for vertical and cross flow of the tool heads and a screw for elevating the rail.

## **TOOL HEAD:**

- › The tool head of the planer is similar to that of a shaper in construction and operation.

## **CLAMPING OF JOB:**

- › There are three important points to be hosted while clamping the job on the planer table.
- › The work should be connected rigidly to the table so that it may not be shifted out of its position while cutting progresses.
- › Proper clamping should be done all round the job.
- › The job should be so held that the surface planed should remain in proper position with other surface.
- › The job may be located on the planning machine table by the following methods.
- › By standard clamping devices.
- › By special fixtures.
- › The standard clamping devices are t-bolts, stops, planer jacks, heavy duty vises, angle plates & planner centres etc.

## **PLANER TOOLS:**

- › The cutting tools which are uses in planer are single point cutting tool which are used in lathe and shaper.
- › Planer tools may be solid for get type or bit type.
- › The bit may be brazed, welded or mechanically held on a m.s bar.
- › As a planer tool has to take up heavy cuts, the tools are made fevaier and larger in cross section.

## Chapter-6



# Milling Machine

### **Milling machine:**

A milling m/c is a type of metal cutting device which remove metal with a fast rotating multi-touch cutter.

As this m/c yield high production of different varieties of jobs, in choice for production m/c, comes after the lathe.

Generally smaller jobs are employed for machining in milling m/c. If larger jobs are handled, then the m/c will perhaps be slower.



# MANUFACTURING TECHNOLOGY

---

Because of using multi tooth cutters & various forms of cutters, a milling m/c can be economically employed for generating various surfaces quite speedily.

## **Types of milling m/c:**

Milling m/c are available in various basing covering a wide range of work & capacities. The choice for a particular m/c depends on the nature & size of the work to be undertaken.

- a) Column & knee type. Milling m/c.
  - a. Hand milling m/c
  - b. Plain milling m/c
  - c. Universal milling m/c
  - d. Omniversal milling m/c
  - e. Vertical milling m/c
- b) Manufacturing/ fixed bed type. Milling m/c
- c) planer type milling m/c
- d) Special type milling m/c.
  - a. Rotary table machine.
  - b. Drum milling m/c.

## **Milling attachment:**

It is a rotary table types work holding device bolted on the table. It provides a rotary motion to the w/p in addition to longitudinal, cross & vertical motions.

## **Dividing head/indexing head:**

Indexing is an operation of dividing a periphery of a cylindrical w/p into equal no. Of divisions by the help of index crank & index plate.

Indexing is accomplished by using a special attachment known as dividing head/indexing head.

Dividing heads are 3 types

1. **Plain/simple dividing head:**
2. **Universal dividing head**
3. **Optical dividing head.**

## Plain/ simple dividing head:

- It has a spindle which carries job holding devices such as three jaw chuck, face plate with centre carrier
- A worm wheel is rigidly fixed on spindle. While an indexing crank is mounted on the worn shaft such that the rotation of index crank finally results in the rotation of the spindle.
- In a plane dividing head, its spindle rotates only around horizontal axis.
- The index plate remains fixed & does not rotate only around horizontal axis.
- The index plate remains fixed & does not rotate while performing simple indexing operation.

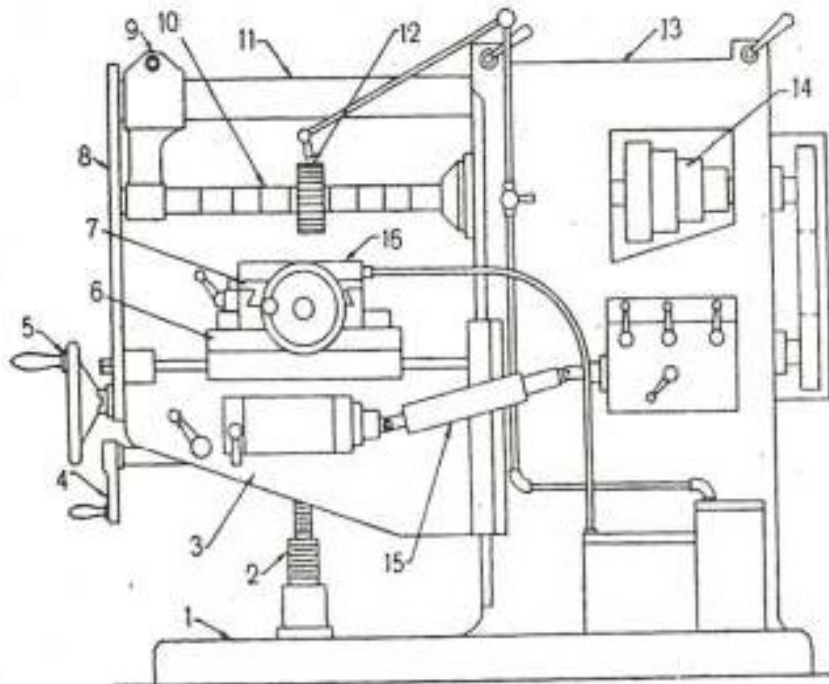

**Figure 11.1 Column and knee type milling machine**

1. Base, 2. Elevating screw, 3. Knee, 4. Knee elevating handle, 5. Crossfeed handle, 6. Saddle, Table, 8. Front brace, 9. Arbor support, 10. Cone pulley, 15. Telescopic feed shaft.

# MANUFACTURING TECHNOLOGY

---

The amount of the spindle relative to the worm depends on the ratio between the relations of worm & the worm wheel.

The most common ratio is 40:1, which means 40 revolutions of index crank or worm will move the worm wheel or spindle through one complete revolution.

## **Universal dividing head:**

- > It is the most commonly used type of attachment on the milling m/c.
- > It is used for the following purposes.
- > Setting the w/p in horizontal, vertical & inclined positions relative to the milling m/c table.
- > Turning the work periodically through a given angle per forming indexing of the work.
- > Imparting a continuous rotary motion to the w/p for milling helical grooves.
- > Dividing head spindle is connected with the table feed screw through a gear train attachment to impart a continuous rotary motion to the w/p for helical milling.
- > Working mechanism of an universal dividing head is the crank which is rigidly fixed at one end of the work shaft, while the bevel gear runs free on the worm shaft.
- > The index plate is bolted with gear & can be locked against the rotation of lock pin.

## **Optical dividing head:**

It is used for high precision angular indexing of the job with respect to the cutter.

For reading the angle, an optical system is built into the dividing head.

## **Spindle:**

Spindle is located in the upper part of the column.

It gets driving power from motor to transmit it to the arbor.

The front end of the spindle just projects from the column face & is provided with a tapered hole to accommodate various cutting tools & arbors.

# MANUFACTURING TECHNOLOGY

---

## **Arbour:**

The arbor is connected with a spindle through a bolt, which serves as an extension of the m/c spindle on which milling cutters are safely mounted & rotated

It is taper shank for proper alignment with the spindle having tapered hole at its nose.

## **Work holding devices:**

Work holding device used on a milling m/c includes the following: Vices which may be plain vice, swivel vice & tool maker's universal vice.

- **Angle plates.**
- **v-blocks**
- **special fixtures.**

## **Work holding attachment:**

Special attachments are used on milling m/c for performing different typical operations. Common attachments include:

- a. Vertical milling attachment: used for facilitating the horizontal spindle milling m/c to do facing on horizontal surface or for making grooves.
- b. Universal milling attachment: similar to vertical attachment with added features for swivelling the spindle about two mutually perpendicular axis.

## **slitting attachment :**

used for converting rotational motion of the horizontal spindle m/c into up & down vertical reciprocating motions. The slotting head is fitted to the spindle & is used for cutting slats. The attachment can be swivelled to any angular positions.

## **high speed milling attachment:**

it is a gearing system used for increasing the spindle speed by four to six times. The attachment is bolted to the face of the column.

# MANUFACTURING TECHNOLOGY

---

## **Rack milling attachment:**

It is bolted to the face of the column. Used for cutting rake teeth.

## **Differential Indexing :**

Available no. Of index plates with different hole circles sometimes limit the range of plate indexing. In such case differential indexing is found useful. In this process, the indexing plate rotates itself in relation to the crank during the process of indexing. For making necessary calculation to find the change gears to be placed between the spindle and the power shaft use the following relation

Where  $N$  = no. Of divisions to be indexed

$n$  is a no. Of slightly or less than  $N$ . After simplification, the above relation  $n$  will give the gear ratio between the gears to be placed on the spindle (driver) and the own shaft (driver).

Gears may be arranged in a simple train or in a compound train as the case may be.

When  $(n - N)$  is positive, the index plate must rotate in the direction in which the crank is rotated.

If  $(n - N)$  is negative the index plate rotates in the opposite direction to that of the crank.

## **Dividing head attachment:**

A dividing head attachment is also a special work holding device which is bolted on the machine plate. The work may be mounted on a chuck fitted on the dividing head spindle or may be supported between alive or dead centre.

The dead centre is mounted on a foot stock as in a lathe tail stock that is bolted on the machine table after after correctly aligning its spindle axis with the dividing heads. spindle

### **Universal dividing head:**

The attachment is similar to the vertical attachment but it has an added arrangement for swivelling the spindle about two mutually perpendicular axes. This feature of the attachment permits the cutting spindle axis to swivel at practically any angle and machine any compound angle surface of the work. The attachment is supported by the over-ram and operates at either the same speed or at higher speed than the scope of machine.

## Chapter-7



### **SLOTTER**

It is used for cutting grooves, key ways and slots of various shapes for making regular and irregular surfaces both internal and external.

Difference between slotter and shaper:

<b>SLOTTER</b>	<b>SHAPER</b>
The ram holds the tool and reciprocates in a vertical axis	The ram holds the tool and reciprocates in a horizontal axis.

## SLOTING MACHINE PARTS:

### **Base/bed:**

The base of the machine is rigidly built to withstand all cutting forces and entire load of the machine.

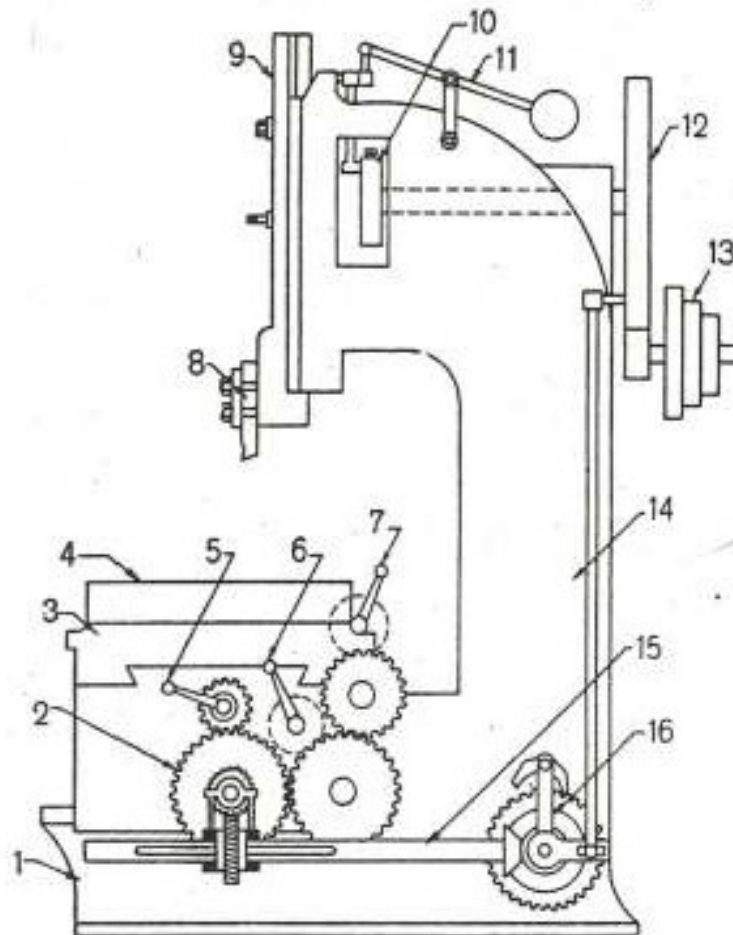

**Figure 9.1 Slotting machine**

1. Base, 2. Feed gear, 3. Cross-slide, 4. Table, 5. Crossfeed handle, 6. Longitudinal feed handle, 7. Circular feed handle, 8. Tool, 9. Ram, 10. Crank disc, 11. Lever for counterbalance weight, 12. Bull gear, 13. Cone pulley, 14. Column, 15. Feed shaft, 16. Pawl actuating crank.



# MANUFACTURING TECHNOLOGY

---

## **COLUMN:**

- The column is the vertical member which is cast integral with the base.
- Driving mechanism and feeding mechanism are inside the column.
- The front vertical face of column is accurately finished for providing ways on which the ram reciprocates.

## **SADDLE:**

- The saddle is mounted upon the guideways and may be moved towards or away from the column either by power/ manual control to supply longitudinal feed to the work.
- The top surface of the saddle is accurately finished to provide guide ways for the cross slide.
- These guideways are perpendicular to the guide ways on the base.

## **CROSS SLIDE:**

- The cross slide is mounted upon the guide ways of the saddle and may be moved parallel to the face of the column. The movement of the slide may be controlled either by hand or power to supply cross feed.

## **ROTATING TABLE:**

- The rotating table is a circular table which is mounted on the top of the cross slide. The table may be rotated by rotating a worm which meshes with a worm gear connected to the underside of the table.
- In some machines the table is graduated in degrees that enable the table to be rotated for indexing.
- T-slots are cut on the top face of the table for holding the work by different clamping devices.
- The rotary table enables a circular or contoured surface to be generated on the work piece.

## **RAM & TOOTHED ASSEMBLY:**

- The ram is the reciprocating member of the machine mounted on the guide ways of the column.
- It supports the tool at its bottomed on tool head.

# MANUFACTURING TECHNOLOGY

---

## **RAM DRIVE MECHANISM:**

- A slotter removes metal during downward cutting stroke only whereas during upward return stroke no metal is removed.
- To reduce the idler time quick return mechanism is incorporated in the machine.

## **FEED MACHANISM:**

- The teed is given by the table.
- A slotting machine table has 3 types of feed movements.

## **LONGITUDINAL:**

- If the table is fed perpendicular to the column towards or away from face the feed movement is termed as longitudinal.

**CROSS:** If the table is feed parallel to the face of the column the feed movement is termed as cross.

**CIRCULAR:** If the table is rotated on a vertical axis the feed movement is circular.

## **SLOTTER TOOLS:**

⊞ top rake angle

⊞ from clearance angle

- In a slotter the pr. Acts along the length of the tool.
- In slotter tool the angles are provided for better cutting.
- The nose of the tool projects slightly beyond the shank to provide clearance.
- The slotter tools are robust in cross section and usually of forged type.
- Bit type tools are fitted in heavy duty tool holders.
- Key way cutting tools are thinner at the cutting edges.
- Round nose tools are used for machining circular/ contoured surfaces.
- Square nosed tools are used for machining flat surfaces.

## Chapter-8

# Grinding

### Grinding M/C:

- Grinding is the process of removing material from work piece. The removing of material from the W/P is either two end its diametre within very closed tolerance (0.02mm) or to give a fine finish or the work surface.
- The grinding machine supports and rotates the grinding wheel for smooth operation. Grinding machine is used for roughing and finishing flat, cylindrical and conical surface.

# MANUFACTURING TECHNOLOGY

---

- The grinding wheel is made of fine grains of abrasive materials. The grains during the rotation of the wheels remove very small chip[s].
- As the selection of chips remove is very small and high cutting speed are involved, the grinding operation results into a very good finish or the work surface and high accuracy in work dimensions.

## **Types of Grinding:**

Oftenly used to grind casting and weldments using portable grinders or pedestal; grinder

## **Fine Grinding :**

- It is applied for finishing of those materials which are too hard to be machined by other methods of metal cutting.
- It is also used for producing surface on the job to attain higher dimensional accuracy and finish

## **BED/BASE**

- It is a heavy cast iron construction and support s other parts of the slotting machine such as column, ram and its driving mechanism, table etc.
- The top of the base is accurately finished to provide guide ways for mounting of the saddle. The cross-slide guide ways are perpendicular to the column face.

## **Column**

- It is a vertical structure cast integral with the base.
- It houses the mechanism for driving ram and feeding mechanism.
- The front vertical face of the column carries guide ways for ram to reciprocating upon it

## **Saddle:**

- It is mounted upon guide ways and can be moved towards or away from the column
- The saddle carries guide ways for cross-slide
- The feed is given by manual or power.

## **Cross-slide:**

- It is mounted upon guide ways made at the top of the saddle and can be moved parallel to the front face of the column.
- Feed is given manual or by power.
- Table
- It is a circular rotary table mounted on the top of the cross-slide
- A circular feed handle for the table is provided
- Rotation of the table is effected by hand or by power
- The table carries T-slots to help mounting of jobs on the table
- Ram and tool head
- They reciprocates up and down on the guide ways made on the front face on the column.
- The ram carries a tool head at its bottom end.
- In some mechanism special tool head is provided to relieve the tool during its return stroke
- A quick return mechanism is given with the machine which enables the return or ideal stroke to be completed faster than the cutting stroke

## **Methods of grinding:**

According to type surface to be grounded main kinds of grinding methods are as follow:

External cylindrical grinding: produces a straight or tapered surface on a w/p when it is rotated about its own axis between centers as it passes lengthwise across the face of a revolving grinding wheel.

Internal cylindrical grinding: it produces internal cylindrical holes & tapers. The work is chucked & rotated on its axis, while the grinding wheel rotates against the work.

## **Surface grinding:**

It produces flat surfaces & the work may be grounded either by periphery or by end face of the grinding wheel.

# MANUFACTURING TECHNOLOGY

---

## **Face grinding:**

It is a method of grinding vertical flat surface & the wheel spindle may be vertical or horizontal.

## **Form grinding:**

It is done by specially shaped grinding wheels to grind formed surfaces as gear teeth, threads, shaft, dovetails etc.

## **Set wheel grinding:**

It is a method of grinding short w/p without changing the grinding wheel.

## **Centre less grinding:**

It is a method of grinding external & internal cylindrical surfaces in which the work is supported among a regulating wheel, a grinding wheel & a work rest blade.

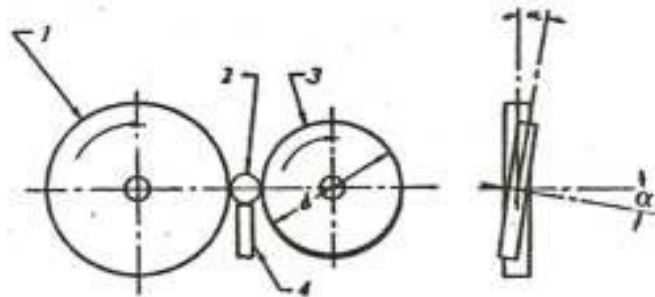

**Figure External centreless grinding**  
1. Grinding wheel, 2. Work, 3. Regulating wheel, 4. Work-rest.

## **Off-hand grinding:**

It is rough grinding method in which work is held in hand and pressed

Against the rotating grinding wheel. For example grinding a chisel on pedestal grinder

## **Types of grinding machine:**

Grinding machine may be broadly classified as follows

1. **Surface grinder**
2. **Cylindrical grinder**
3. **Center-less grinder**
4. **Portable grinder**
5. **Pedestal grinder**
6. **Cutter and tool grinder**
7. **Internal grinder**
8. **Flexible shaft grinder**

### **Surface grinder :**

- a. It is used for grinding flat surfaces
- b. Surface grinding effective for removing hard spots and sets from the work surface
- c. Surface grinding machine differs according the shape of grinding wheel and motion given to the work table during working.
- d. Some common type surface grinding machine are prescribed in the following

### **Horizontal spindle surface grinding machine:**

It is used for the circumference of a straight grinding wheel and are able to handle a wide range of work with super finish and externally fine limits of accuracy

### **Vertical spindle flat grinding machine:**

These are strongly built machine. They yield more out put with cup type wheel rather than using of straight wheels.

### **Disc grinding machine:**

These are used for rough semi precision grinding rapid removal of metal is done by this type of machine.

## Chapter-9

### Internal Machining operations



## Introduction

The drilling machine is one of the most important machine tools in a workshop. As regards its importance it is second only to the lathe. Although it was primarily designed to originate a hole, it can perform a number of similar operations. In a drilling machine holes may be drilled quickly and at a low cost. The hole is generated by the rotating edge of a cutting tool known as the drill which exerts large force on the work clamped on the table. As the machine tool exerts vertical pressure to originate a hole it is loosely called a "drill press".

Holes were drilled by the Egyptians in 1200 B.C. about 3000 years ago by bow drills. The bow drill is the mother of present day metal cutting drilling machine.

## TYPES OF DRILLING MACHINE

Drilling machines are made in many different types and sizes, each designed to handle a class of work or specific job to the best advantage. The different types of drilling machines are :

1. Portable drilling machine.
2. Sensitive drilling machine.
  - (a) Bench mounting,
  - (b) Floor mounting
3. Upright drilling machine.
  - (a) Round column section,
  - (b) Box column section
4. Radial drilling machine.
  - (a) Plain
  - (b) Semiuniversal
  - (c) Universal
5. Gang drilling machine.
6. Multiple spindle drilling machine.
7. Automatic drilling machine.
8. Deep hole drilling machine.
  - (a) Vertical
  - (b) Horizontal

## PORTABLE DRILLING MACHINE

As the name implies this type of drilling machine can be operated with ease any where in the workshop and is used for drilling holes in workpieces in any position which can not be drilled in a standard drilling machine. Some of the portable machines are operated by hand power, but most of the machines are driven by individual motor. The entire drilling mechanism including the motor is compact and small in size. The motor is usually of universal type which may be driven by both A.C. and D.C. The maximum size of the drill that it can accommodate is not more than 12 to 18 mm. The machine is operated at high speed as smaller size drills are only used. Some of the portable machines are driven by pneumatic power.

## SENSITIVE DRILLING MACHINE

The sensitive drilling machine is a small machine designed for drilling a small holes at high speed in light jobs, The base of the machine may be mounted on a bench or on the floor. It consists of a vertical column, a horizontal table, a head supporting the motor and driving mechanism, and a vertical spindle for driving and rotating the drill. There in no arrangement for any automatic feed of the drill spindle. The drill is fed into the work by purely hand control. High speed and hand feed are necessary for drilling small holes. High speeds are necessary to attain required cutting speed by small diameter drill. Hand feed permits the operator to feel or sense the progress of the drill into the work, so that if the drill becomes worn out or jams on any account, the pressure on the drill may be released immediately to prevent it from

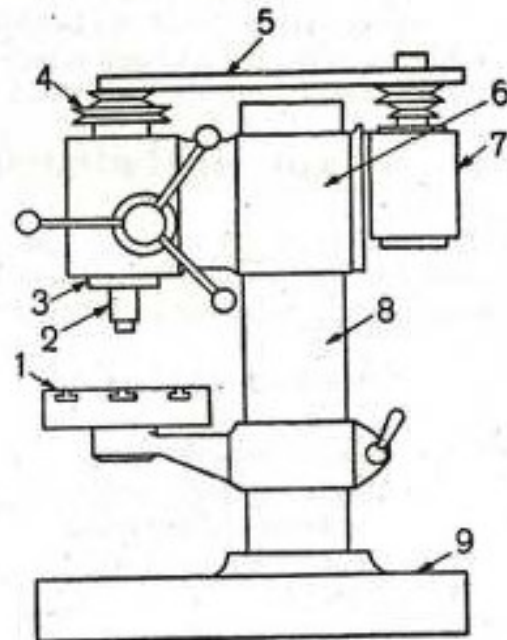

**Figure Sensitive drilling machine**  
1. Table, 2. Vertical drill spindle, 3. Sleeve, 4. Cone pulley, 5. V-belt, 6. Head, 7. Driving motor, 8. Vertical column, 9. Base.

breaking. As the operator senses the cutting action, at any instant, it is called sensitive drilling machine. Sensitive drilling machines are capable of rotating drills of diameter from 1.5 to 15.5 mm. Super sensitive drilling machines are designed to drill holes as small as 0.35 mm in diameter and the machine is rotated at a high speed of 20,000 r.p.m. or above. Fig.5.1 illustrates a sensitive drilling machine.

### UPRIGHT DRILLING MACHINE

The upright drilling machine is designed for handling medium sized workpieces. In construction the machine is very similar to a sensitive drilling machine for having a vertical column mounted upon the base. But this is larger and heavier than a sensitive drill and is supplied with power feed arrangement. In an upright drilling machine a large number of spindle speeds and feeds may be available for drilling different types of work. The table of the machine also have different types of adjustments. There are two general classes of upright drilling machine:

1. Round column section or pillar drilling machine.
2. Box column section.

**Round column section or pillar drilling machine :** The round column section upright drilling machine or pillar drilling machine consists of a round column that rises from the base which rests on the floor, an arm and a round table assembly, and a drill head assembly.

The arm and the table have three adjustments for locating workpieces under the spindle. The arm and the table may be moved up and down on the column for accommodating workpieces of different heights. The table and the arm may be moved in an arc upto  $180^\circ$  around the column and may be clamped at any position. This permits setting of the work below the spindle. Moreover, heavy and odd-size work may be supported directly on the base of the machine and drilled after the arm is swung out of the way. The table may be rotated  $360^\circ$  about its own centre independent of the position of the arm for locating workpieces under the spindle.

The construction of the machine being not very rigid and the table being supported on a horizontal arm, this is particularly intended for lighter work. The maximum size of holes that the machine can drill is not more than 50 mm.

**Box column section upright drilling machine :** The upright drilling machine with box column section has the square table fitted on the slides at the front face of the machine column. Heavy box column gives the machine strength and rigidity. The table is raised or lowered by an elevating screw that gives additional support to the table. These special features permit the machine to work with heavier workpieces, and holes more than 50 mm in diameter can be drilled by it.

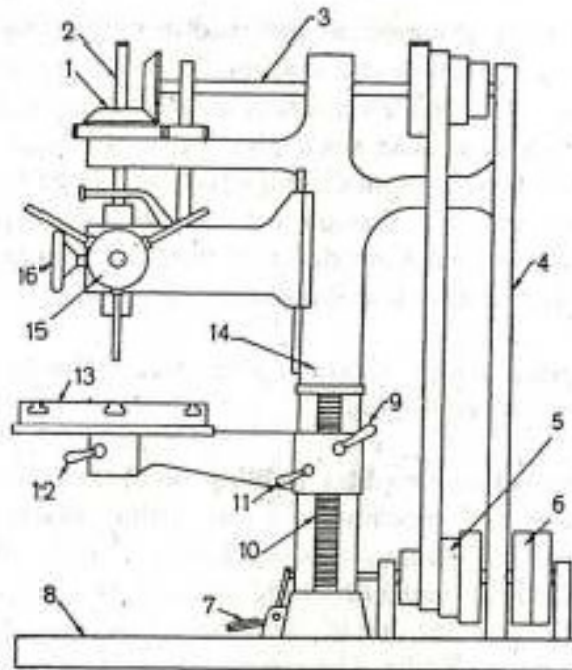

**Figure Upright pillar drilling machine**

1. Bevel gear drive to spindle, 2. Spindle, 3. Overhead shaft, 4. Back stay, 5. Counter shaft cone pulley, 6. Fast and loose pulley, 7. Table elevating handle, 8. Foot pedal, 9. Base, 10. Rack on column, 11. Table elevating clamp handle, 12. Table clamp, 13. Table, 14. Column, 15. Handwheel for quick hand feed, 16. Handwheel for sensitive hand feed.

### RADIAL DRILLING MACHINE

The radial drilling machine is intended for drilling medium to large and heavy workpieces. The machine consists of a heavy, round, vertical column mounted on a large base. The column supports a radial arm which can be raised and lowered to accommodate workpieces of different

heights. The arm may be swung around to any position over the work bed. The drill head containing mechanism for rotating and feeding the drill is mounted on a radial arm and can be moved horizontally on the guide-ways and clamped at any desired position. These three movements in a radial drilling machine when combined together permit the drill to be located at any desired point on a large workpiece for drilling the hole. When several holes are drilled on a large workpiece, the position of the arm and the drill head is altered so that the drill spindle may be moved from one position to the other after drilling the hole without altering the setting of the work. This versatility of the machine allows it to work on large workpieces. The work may be mounted on the table or when the work is very large it may be placed on the floor or in a pit. Fig.5.3 illustrates a radial drilling machine.

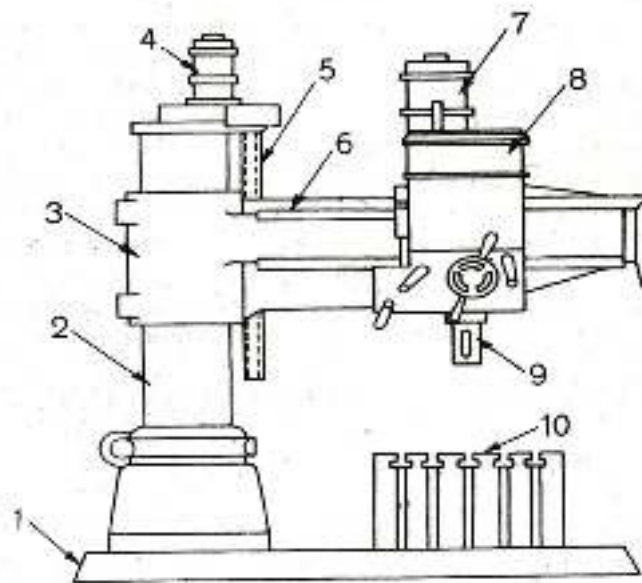

**Figure Radial drilling machine**

1. Base, 2. column, 3. Radial arm, 4. Motor for elevating the arm, 5. Elevating screw, 6. Guide ways, 7. Motor for driving the drill spindle, 8. Drill head, 9. Drill spindle, 10. Table

**Plain radial drilling machine :** In a plain radial drilling machine provisions are made for vertical adjustment of the arm, horizontal movement of the drill head along the arm, and circular movement of the arm in horizontal plane about the vertical column.

**Semiuniversal machine :** In a semiuniversal machine, in addition to the above three movements, the drill head can be swung about a horizontal axis perpendicular to the arm. This fourth movement of the drill head permits drilling hole at an angle to the horizontal plane other than the normal position.

**Universal machine :** In a universal machine, in addition to the above four movements, the arm holding the drill head may be rotated on a horizontal axis. All these five movements in a universal machine enables it to drill on a workpiece at any angle.

The boring machine is one of the most versatile machine tools used to bore holes in large and heavy parts such as engine frames, steam engine cylinders, machine housings, etc. which are practically impossible to hold and rotate in an engine lathe or a drilling machine. Boring machines have, therefore, been developed primarily to do this. In addition to its primary purpose of boring the range of speeds and feeds provided to the various traversing components allow drilling, milling and facing to be performed with equal facility. By the fitting of simple attachments, the use of the machine can be extended still further to include screw cutting, turning, planetary grinding, or gear cutting.

### TYPES OF BORING MACHINES

The boring machines may be classified under the four headings :

1. Horizontal boring machine.
  - (a) Table type.
  - (b) Floor type.
  - (c) Planer type.
  - (d) Multiple head type.
2. Vertical boring machine.
  - (a) Vertical turret lathe.
  - (b) Standard vertical boring machine.
3. Precision boring machine.
4. Jig boring machine.
  - (a) Vertical milling machine type.
  - (b) Planer type.

### HORIZONTAL BORING MACHINE

In a horizontal boring machine, the work is supported on a table which is stationary and the tool revolves in a horizontal axis. A horizontal boring

machine can perform boring, reaming, turning, threading, facing, milling, grooving, recessing and many other operations with suitable tools. Workpieces which are heavy, irregular, unsymmetrical or bulky can be conveniently held and machined. Different types of horizontal boring machines have been designed to suit different purposes. Fig.6.1 illustrates a horizontal boring machine.

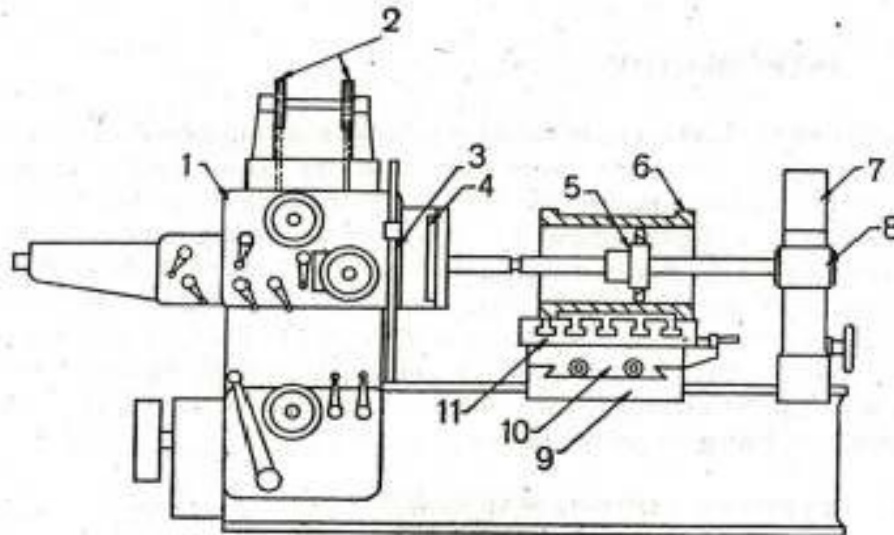

**Figure Horizontal boring machine**

1. Headstock, 2. Pulley for counter balancing weight of headstock, 3. Headstock elevating screw, 4. Boring head, 5. Boring cutter on boring bar, 6. Work, 7. End supporting column, 8. Bearing block, 9. Saddle, 10. Cross-slide, 11. Table.

**Table type horizontal boring machine :** The table type is the most common of all horizontal boring machines. This is so named, because the work is mounted on the table which is adjustable and feed is given by hand or power, lengthwise or crosswise with respect to the bed of the machine. The headstock may be adjusted vertically on the column and the spindle has a horizontal feed

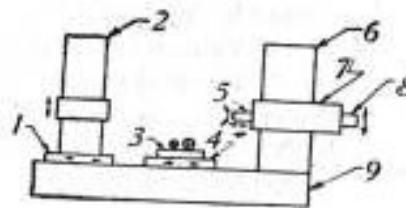
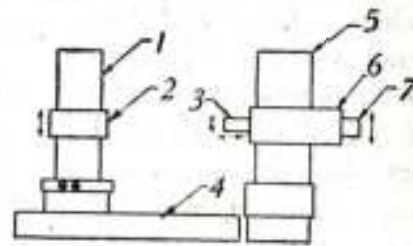

**Figure Table type horizontal boring machine**

1. Column base, 2. End supporting column, 3. Table, 4. Saddle, 5. Spindle, 6. Headstock supporting column, 7. Headstock, 8. Motor, 9. Bed.

motion. The machine essentially consists of a bed, headstock supporting column, end supporting column, headstock, saddle and table, and boring bar. The table, saddle and headstock may be adjusted by leadscrews using micrometer dials. This type of machine is suitable for general purpose work where other operations, in addition to boring, are required to be performed. A block diagram of a table type machine is shown in Fig.6.2.

**Floor type horizontal boring machine :** The floor type horizontal boring machine having no table uses a stationary floor-plate on which T-slots are provided to hold the work. The headstock supporting column and the end supporting column and the end supporting column are mounted on the runways which are placed at right angles to the spindle axis. Thus any crosswise adjustment or cross-feed movement is provided by the spindle itself and not by the work. This is so designed for holding very large and heavy workpieces which are difficult to be mounted and adjusted on a table. A block diagram of a floor-type machine is shown in Fig.6.3.



**Figure Floor type horizontal boring machine**

1. End supporting column, 2. Column base, 3. Spindle, 4. Floor plate, 5. Headstock, 7. Motor.

**Planer type horizontal boring machine :** The planer type horizontal boring machine resembles the table type but table slides directly on the bed instead of on a saddle and reciprocates at right angles to the spindle similar to a planer. The end supporting column and headstock supporting column may be adjusted towards or away from the table for accommodating different widths of work. This type of machine is suitable for supporting a long work. A block diagram of a planer type machine shown in Fig.6.4.

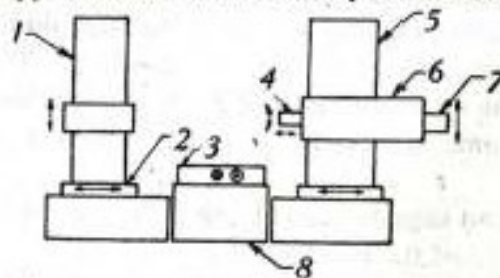
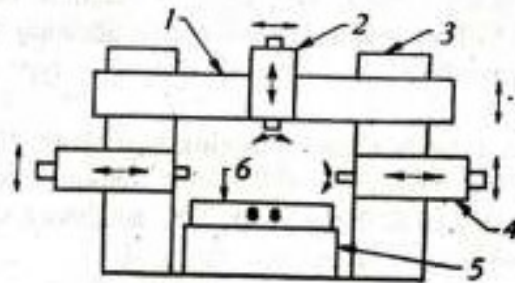

**Figure Planer type horizontal boring machine**

1. End supporting column, 2. Column base, 3. Table, 4. Spindle 5. Headstock supporting column, 6. Headstock, 7. Motor, 8. Bed.



**Multiple head type horizontal boring machine :** The machine resembles a double housing planer or a plano-miller. The table is supported on a long bed on which it reciprocates. There are two vertical columns at two sides of the bed, nearly at the middle of the bed. The two columns are bridged by a crossrail. The machine may have two, three or four headstocks. This type of machine may be used both as a horizontal and vertical machine. The machining operations can be performed simultaneously at different work surfaces. A block diagram of the machine is shown in Fig.6.5.



**Figure Multiple head type horizontal boring machine**  
1. Crossrail, 2,4. Headstocks, 3. Column, 5. Bed, 6. Table.

## PART OF A HORIZONTAL BORING MACHINE

The different parts of a horizontal; boring machine are illustrates in Fig.

**Bed :** The bed is that part of the machine which is fitted on the floor of the shop and has a box like casting. The bed supports the columns, tables and other parts of the machine.

**Headstock supporting column :** The column provides support to the headstock and guides it up and down accurately by the guide ways provided on the face of the column. The column which is hollow houses the counterweights of the headstock, and is heavily ribbed to add rigidity. Some columns are stationary, others may be made to slide along the bed.

**End supporting column :** The end supporting column situated at the other end of the bed houses the bearing block for supporting a long boring bar. The column may be adjusted on the sideways of the bed towards or away from the spindle for supporting different lengths of boring bars or it may be moved at right angles to the spindle as in the case of a floor type machine.

**Headstock :** The headstock mounted on the column supports, drives, and feeds the tool. The spindle revolves within a quill. The spindle provides

## SIZE OF A HORIZONTAL BORING MACHINE

The size of a horizontal boring machine is specified by the diameter of its spindle in mm. The diameter of the spindle varies from 75 to 355 mm. To specify a boring machine fully other important dimensions such as spindle motor horse power, column heights, size of the table or size of the floor plate, spindle speeds, feeds and length of feeds, floor space required, weight of the machine, etc. should also be stated.

## BORING MACHINE MECHANISM

The machine contains different controls for movements of the different parts of the machine. A table type machine has the following movements :

1. The headstock and the end supporting block may be moved up and down.
2. The spindle may be rotated. The spindle has different speeds.
3. The spindle may be, moved in or out by hand or power for feeding.
4. The saddle and the table may be moved by hand or power.
5. The columns may be moved by hand or power.

## BROACHING METHODS

Broaching, according to the method of operation, may be classified as follows :

1. **Pull broaching** : The work is held stationary and the broach is pulled through the work. Broaches are usually long and are held in a special head. Pull broaching is used mostly for internal broaching but it can do some surface broaching.
2. **Push broaching** : The work is held stationary and the broach is pushed through the work. Hand and hydraulic arbor presses are popular for push broaching. This method is used mostly for sizing holes and cutting keyways.
3. **Surface broaching** : Either the work or the broaching tool moves across the other. This method has rapidly become an important means of surface finishing. Many irregular or intricate

shapes can be broached by surface broaching, but the tools must be specially designed for each job.

4. **Continuous broaching** : The work is moved continuously and the broach is held stationary. The path of movement may be either straight horizontal or circular. This method is very suitable for broaching a number of similar works at a time.

### BROACHING MACHINES

Broaching machines are probably the simplest of all machine tools. They consist of a work holding fixture, a broaching tool, a drive mechanism, and a suitable supporting frame. Although the component parts are few, several variations in design are possible. There are two principal types of machines : horizontal and vertical. In addition to these standard types, there are special and continuously operating machines. Both horizontal and vertical types have one or more rams depending on production requirement. Dual-ram models are arranged so that when one ram is on the cutting stroke, the other is on the return stroke ; and the return stroke is performed quickly to gain time, which is used to unload and load the machine.

Broaching machines usually pull or push the broach through, or past a workpiece that is held in a fixture. On some machines, however, the workpiece is moved past a broach that is fixed in its position. Most broaching machines are hydraulically operated to secure a smooth, uniform cutting action.

**Horizontal broaching machines** : Nearly all horizontal machines are of the pull type. They may be used for either internal or external broaching, although internal work is the most common. A horizontal broaching machine shown in Fig. 15.5 consists of a bed or a base a little more than twice the length of the broaching stroke, a broach pilot and the drive mechanism for pulling the broach.

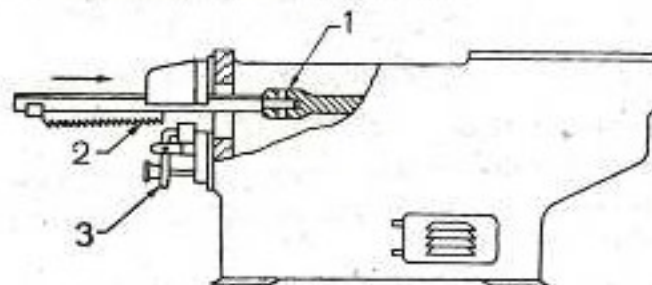

**Figure** Horizontal broaching machine  
1. Pulling head, 2. Broach, 3. Work fixture.

Horizontal broaching machines are used primarily for broaching keyways, splines, slots, round holes, and other internal shapes or contours. They have the disadvantage of taking more floor space than do the vertical machines.

However, long broaches and heavy workpieces are easily handled.

**Vertical broaching machines :** The vertical types may be obtained in either push or pull type. The push type is the most popular. A vertical broaching machine is shown in Fig.15.6. Vertical machines are employed in multiple operations, since they are convenient to pass work from one machine to another, and they are more likely to be found doing surface operations. Of the three models available, pull up, pull down, and push down, the pull up type is most popular.

Vertical machines require an operator platform or a pit and are economical of floor space than the horizontal type.

Modern vertical broaches are offered with both hydraulic and electro-mechanical drives. But hydraulic drives are the most common because they cost less. A vertical hydraulic broaching machine is illustrated in Fig.

**Surface broaching machine :** Surface broaching machines have their broaching tools attached to a ram or rams forced in a straight path along guideways past the workpiece. On some machines the ram moves horizontally, on others vertically. When two rams are used, the machine is called a *duplex broach*.

**Continuous broaching machines :** For mass production of small parts, the highly productive continuous-broaching method is used on rotary or horizontal continuous-broaching machines. They are illustrated in Fig.

In the *rotary continuous broaching machines*, the workpiece is loaded on the table which rotates continuously. During the operation the broach is stationary.

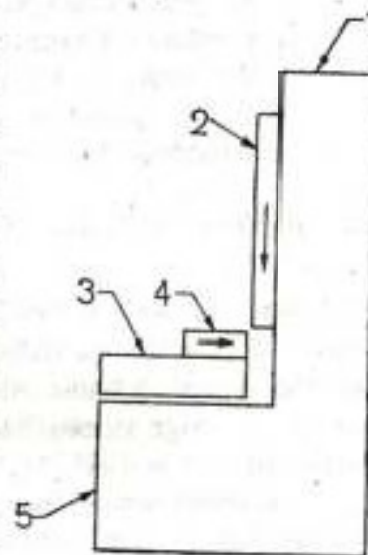

**Figure** Block diagram of a vertical broaching machine

1. Column, 2. Broach, 3. Fixture and table, 4. Work, 5. Base.

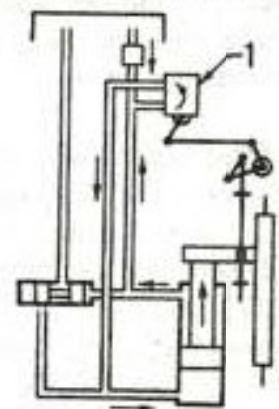

**Figure** The hydraulic circuit for a vertical

The teeth of a gear or splint may be broached altogether or one or a few at a time. A comparatively simple broach can be made to cut one or a few tooth spaces. After one pass, the gear blank is indexed, and more of its teeth are cut. Successive passes are made until all the teeth are finished.

### ADVANTAGES AND LIMITATIONS OF BROACHING

Broaching has been adopted for mass production work because of the following outstanding features and advantages :

1. Rate of production is very high. With properly applied broaches, fixtures, and machines, more pieces can be turned out per hour by broaching than by any other means.
2. Little skill is required to perform a broaching operation. In most cases the operator merely loads and unloads the workpiece.
3. High accuracy and a high class of surface finish is possible. A tolerance of  $\pm 0.0075$  mm and a surface finish of about 0.8 microns (1 micron = 0.001mm) can be easily obtained in broaching.
4. Both roughing and finishing cuts are completed in one pass of the tool.
5. The process can be used for either internal or external surface finishing.
6. Any form that can be reproduced on a broaching can be machined.
7. Cutting fluid may be readily applied where it is most effective because a broach tends to draw the fluid into the cut.

Certain reasons, however, limit the application of the broaching process. They are :

1. High tool cost. A broach usually does only one job and is expensive to make and sharpen.
2. Very large workpieces cannot be broached.
3. The surfaces to be broached cannot have an obstruction.
4. Broaching cannot be used for the removal of a large amount of stock.
5. Parts to be broached must be capable of being rigidly supported and must be able to withstand the forces that set up during cutting.

## Chapter-10

### Surface finish, lapping

#### **Introduction:**

In a manufacturing plant, a product may be shaped, turned, milled or drilled, and left in that condition as being satisfactory for use. However, if a better finish is desired, for looks, for accuracy, for wearing qualities, or for any other reasons, one of the micro finished that include lapping, honing, super finishing, polishing, buffing, may be employed. In some cases other operations are done only to get durable finishes.

### **LAPPING:**

Lapping is an abrading process that is used to produce geometrically true surfaces, correct minor surface imperfection, improve dimensional accuracy, or provide a very close fit between two contact surfaces. Very thin layers of metal (0.005 to 0.01mm) are removed in lapping and it is therefore, evident that it is unable to correct substantial error in the form and size of surface, it is however low efficiency process is used only when specified accuracy and surface finish cannot be obtained by other method. Abrasive powders (floors such as emery, corundum iron oxide, chromium oxide mixed with oil is mixed with oil or special paste with some carrier are used in lapping.

Most lapping is done by means of lapping shoes or quills called laps that are rubbed against the work. The face of a lap becomes 'charged' with abrasive particle. Charging a lap means to embed the abrasive grains into surface. Laps may be made of almost of any material soft enough to receive and retain the abrasive grains. They are made of soft iron, brass, copper, lead or soft steel.

The method of charging a lap depends upon the shape of lap. When the lap is once charged it should be used without applying more abrasive until it ceases to cut. Lap may be operated by hand or machine, the motion being rotary or reciprocating.

Cylindrical work may be lapped by rotating the work in the lathe or drill press and reciprocating the lap over the work in an ever-changing path. Small flat surfaces may be lapped by holding the work against a rotating disc, or the work may be moved by hand in an

Irregular path over a stationary face plate lap. In equalizing lapping the work and lap mutually improve each other surfaces as they slide on each other.

There are three important types of lapping machines. The vertical axis lapping machine laps flat or round surfaces between two oppose laps on vertical spindle. The centre-less lapping machine is designed for continuous production of round parts such as piston pins, bearing races and cups, valve tappets and shafts.

The centre less lapping machine on the same principle as centre less grinding. The abrasive belt lapping machine lapps bearings and cam surfaces by means of abrasive coated clothes.



# Subject: Manufacturing Technology (Th-2)

4th sem. Mechanical Engg.

## Chapter 1 (Tool Materials)

### Short Questions

- (i) What are different types of Tool Material?
- (ii) What are physical Properties of Tool Material?

### Long question

Explain Composition, properties and uses of different Tool Material

## Chapter 2 (Cutting Tools)

### Short Questions

- (i) Differentiate between single point & multipoint cutting Tool?
- (ii) What are the different machining process parameters of cutting tool?
- (iii) What is the function of Die and reamer?
- (iv) Define tool geometry and purpose of tool angle?

### Long questions

- (i) Explain the cutting action of Chisel and Hacksaw <sup>with sketch</sup>
- (ii) Explain the cutting tool Nomenclature and its different parts with neat sketch?
- (iii) Explain the different types of cutting fluids with its properties and uses during machining operation?
- (iv) Explain the cutting action of Dies and reamer with its function?

## Chapter 3 (Lathe Machine)

### Short Questions

- (i) What is the specification of Lathe Machine?
- (ii) Define Lathe Machine & its functions?
- (iii) What are the safety measures during machining in Lathe?
- (iv) What is the difference bet<sup>n</sup> Capstan and Turret Lathe?
- (v) Define Multiple Tool holders in Lathe?
- (vi) What are the different <sup>major</sup> parts of Lathe M/C?

### Long Questions

- (1) Explain the major parts of Lathe and the different operations carried out in Lathe machine?
- (2) Explain the major components of Turret Lathe and its functions?
- (3) Explain the tooling layout for preparation of a hexagonal bolt and bush?
- (4) Explain the major component of Capstan Lathe and its functions?
- (5) Explain the different taper turning methods in lathe machining operation? Calculate the amount of taper in tailstock setting over method if the  $D = 150\text{mm}$ ,  $d = 100\text{mm}$  and  $L = 500\text{mm}$

## Chapter-4 (Shaper Machine)

### Short Questions

- (1) Define shaper machine and its function?
- (2) What is the specification of a shaper machine?
- (3) What is the application of a shaper M/C tool?

### Long Questions

- (1) Explain the major components of shaper M/C and its functions?
- (2) Explain the Quick Return mechanism of a shaper M/C with neat sketch?
- (3) Explain the automatic table feed mechanism of shaper M/C?
- (4) Explain the construction and working of shaper tool head?

## Chapter-5 (Planner Machine)

### Short Questions

- (i) Define planner M/C tool and its function?
- (ii) What are the different types of planner tools and tool supports?
- (iii) What are the different types of clamping devices used in planner tool?

### Long Questions

- (1) What are the different major components of planner M/C and its functions?
- (2) Explain the difference between planner and shaper M/C tool?

## Chapter - 6 (Milling Machine)

### Short Questions

- (i) Define Milling M/c and its function?
- (ii) What are the uses of Milling Machines?
- (iii) What are the different types of Milling Machine?
- (iv) What is work holding attachment of Milling M/c?
- (v) Define simple indexing & compound indexing?

### Long Questions

- (1) Explain the construction and working principle of column and knee type Milling machine?
- (2) What is the difference bet<sup>n</sup> upmilling and downmilling?
- (3) Explain the construction and working of universal dividing head in Milling M/c?
- (4) Define indexing and explain the procedure of simple indexing?
- (5) Explain compound indexing procedure and calculate the indexing crank movement for 64 divisions of workpiece circumference if the no. of two hole circles are given as  $n = 33$  and  $y = 27$  by using compound indexing method?

## Chapter 7 (Slotted Machine)

### Questions

- (1) Define slotted Machine and its uses?
- (2) Explain the major components and function of slotted Machine tool?
- (3) Explain the construction and working of slotted Machine?
- (4) What are different types of slotted tools?

## Chapter - 8 (Grinding Machine)

### Short Question

- (1) ~~Define~~ Define Grinding Machine and its function?
- (2) What is the Specification of grinding wheel with example?
- (3) What is the Criteria for selection of grinding wheel?
- (4) What are the different types of abrasives used in grinding wheel? (Natural & Artificial Abrasives)
- (5) Explain the manufacturing of Grinding wheel?

### Long Questions

- (1) Explain the different types of bonds used in abrasive of Grinding wheel?
- (2) Explain the working of cylindrical Grinder with sketch?
- (3) Explain the working of Centerless Grinder with diagram?
- (4) What is Surface Grinder, Explain it?

## Chapter-9 (Internal Machining Operation)

### Question

- (1) Explain the working of Bench or sensitive drilling Machine?
- (2) Explain the working of Pillar drilling Machine?
- (3) Explain the Radial drilling m/c with neat sketch?
- (4) Differentiate between Boring and drilling operation?
- (5) Explain the different types of Broaching tool?  
(Pull and Push type)
- (6) What are the different types of boring Machines?
- (7) What are the advantages and limitation of Broaching tool?
- (8) What is the application of Boring & Broaching tool?

## Chapter-10 (Surface Finishing Operation)

### Question

- (i) Define surface finishing operation?
- (ii) What are different types of surface finish operation?
- (iii) Explain the operation of Lapping with its uses?

MANUFACTURING TECHNOLOGY  
(Code: MET-402)

Time: 3 hours

Total Marks: 80

Answer any five questions including Q. Nos. 1 & 2  
Examinee in the right-hand margin indicate marks

- (a) Write major components of lathe and explain about its operations.
  - (b) Explain the difference between shaper and planer machine.
  - (c) Why milling machine is used in industry and explain its working procedure briefly?
  - (d) What are the significance of grinding operation?
  - (e) Explain the difference between boring and honning.
  - (f) Explain the difference between broaching and lapping.
  - (g) Why slotter machine is used and explain types of tools used in it?
3. Explain types of internal machining operation in details. 10
  4. What is super finishing operation, explain its types and uses. 10
  5. What is indexing, and explain simple indexing method? 10
  6. Explain the types of abrasive used in grinding wheels and what are its purpose. 10
  7. Explain tool geometry and purpose of tool angle. 10

## MANUFACTURING TECH.-II

( Theory – 1 )

Full Marks : 80

Time : 3 hours

Answer any five questions including Q. Nos.1 & 2  
which are compulsory

*The figures in the right-hand margin indicate marks*

1. Answer *all* questions : 2 × 10

- (i) Differentiate between a slotter and a vertical shaper.
- (ii) Which is the most versatile m/c tool in a workshop and why ?
- (iii) What are the diff. abrasives used in making a Grinding wheel ?
- (iv) Mention the specification of a shaping machine.
- (v) Define 'Boring'.

( Turn Over )



( 2 )

- (vi) Write down four work holding devices.
- (vii) What are the different methods of taper turning ?
- (viii) Why lead screw in a lathe is square threaded ?
- (ix) What are diff. superfinishing operations ?
- (x) In which operation dividing head is used and for what ?

2. Answer any five questions : 6×5

- 6 (a) What is compound indexing ? Explain with a sketch.
- (b) Differentiate between an engine lathe and a capstan lathe.
- (c) What are the cutters used for milling keyways T-slots and dovetail grooves ?
- (d) Differentiate between cutting speed and feed.

(e) Enlist different parts of a lathe carriage and briefly explain respective functions.

(f) Explain with neat sketch the bar feeding mechanism.

(g) What is lapping ? Briefly explain.

3. With neat sketch describe the parts and function of a radial drilling machine. 10

4. Describe in details about the various type of bonds used in making Grinding wheels. 10

5. Explain the quick return mechanism in case of a hydraulic shaper. 10

6. Show various parts of a Universal milling m/c with block diagram and describe its function. 10

( 4 )

7. Write short notes (any *two*) :

5×2

(i) Puncher slotter

(ii) Face plate

(iii) Chuck.

10/